

Electrochemical Impedance Spectroscopy (EIS) Study of a dye extract.

Abstract

Pt/TiO₂/Dye modified electrode shows two pair of oxidation peaks at 256 and 474 mV which is ascribed to Fe³⁺/Fe²⁺, and a reduction peak of 210 mV which is ascribed to TiO₂/Dye. Internal resistance of the DSSC shows the dye can be strongly adsorbed to the surface of TiO₂, therefore Pt/TiO₂/Dye electrode transfers electron with very minimal resistance making the dye a good sensitizer material for DSSCs.

Introduction

Dye-sensitized Grätzel solar cells have just set a new efficiency benchmark. By changing the composition and colour of the cells, an École Polytechnique Fédérale de Lausanne (EPFL) team has increased their efficiency to more than 12%. A group of scientists in EPFL's Laboratory of Photonics and Interfaces, under the leadership of EPFL Professor Michael Grätzel, has improved the efficiency of Grätzel solar cells to 12.3% (G24 Innovations, 2011). This performance is now comparable to silicon-based solar panels that are on the market today in addition, the costs of using this technology have come down slightly. The challenge was to increase the efficiency of the dye-sensitized cells in order to produce more electricity. To do this, the chemists replaced the standard dye components ruthenium and iodine with porphyrin and cobalt. This combination allows them to increase the absorption of sunlight and results in a more efficient electron exchange. It is this exchange of electrons from the dye to the substrate that produces electricity.

Grätzel cells mimic the process of plant photosynthesis, and these new dye-sensitized cells take the imitation even closer, the new chemical combination gives them a greenish tint. This color increases the efficiency of the process that converts light energy into electricity. To get the most out of the light coming from the sun, the cell absorbs the colors of the spectrum with the highest energies and rejects the rest, which includes the green wavelengths. Grätzel cells can be used to create flexible, transparent solar panels. They're a promising alternative for certain applications in which traditional rigid, silicon-based panels cannot be used. In addition, this new efficiency benchmark brings them well within the efficiency range of silicon cells: the theoretical maximum efficiency of Grätzel cells is now 30%, compared with 26% for silicon cells (G24 Innovations, 2011).

The Mechanism of the Solar Cell

When an incident photon is absorbed by a solar cell of this type it is a molecule of the dye that actually absorbs it, exciting an electron from a lower orbital or energy level to a higher energy level. This higher level has to be slightly higher than the conduction band of the titanium dioxide so that the easiest path for the electron is to fall down to the conduction band and not back to the lower energy level of the dye in which case no energy can be gained. The latter is called recombination. The advantageous alternative process, when the electron is transferred from the dye to the semiconductor is called injection. It is a part of the so-called separation: the electron and its corresponding vacancy are separated from each other, a critical moment for avoiding recombination.

The electron is transported from the dye through the nanoporous structure of the titanium dioxide to the back contact, inducing a current on its way to the counter electrode and there re-entering the cell through the redox-couple in the electrolyte. The redox potential of the electrolyte has to be slightly higher than the lower energy level in the dye from which it was once excited and to which it will now return, waiting for a new photon to excite it to a higher energy level (figure 2).

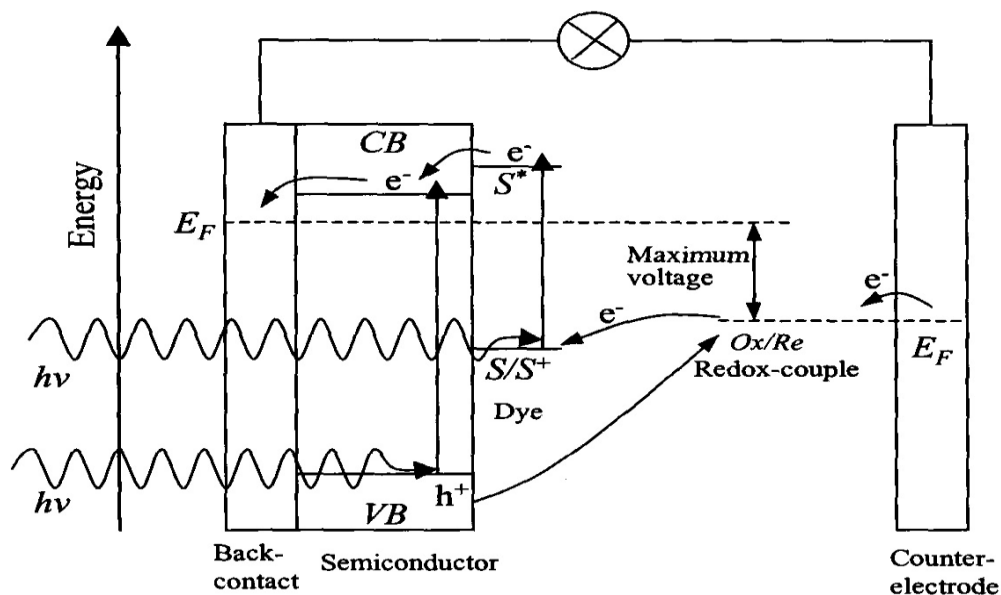

Figure 1: The mechanism of the solar cell.

It is crucial that the relationships between the energy levels in the cell are optimal. In general, the excited electron always seeks to reach a lower energy level in small steps. Only if it can find a favorable path back to its lower original level a part of the voltage difference can be used to produce a current. This description of the solar cell function also points at the importance of stability of the dye so that this cycle can occur again and again.

Molecule-Light Interaction

An electron can be excited from one energy level or orbital to another if it absorbs a photon. The energy difference between the energy level the electron is excited from and the one it is excited to must correspond exactly to the energy of the photon. The energy, ϵ , of a photon is correlated to its wavelength, λ , by the equation

$$\epsilon = hc/\lambda \quad (1)$$

where c is the speed of light in vacuum and h is Planck's constant.

The absorption of light by a molecule can only occur at the specific wavelengths corresponding to the possible transitions in that molecule. Most transitions in nature occur between the Highest Occupied Molecular Orbital (HOMO) and the Lowest Unoccupied Molecular Orbital (LUMO) in a molecule (Atkins and Friedman, 2000), which corresponds to the smallest energy quanta possible to absorb by that molecule. A complex molecule such as a dye has a distribution of electronic states in the HOMO and the LUMO. Thus a number of wavelengths defining the absorption spectra of that molecule can be absorbed.

Colour

Dyes are coloured substances that have affinity to the substrates to which they are being applied. Dyes are generally applied in an aqueous solution and require a mordant to improve the fastness of the dye on the fibre. Dyes appear to be coloured because they absorb some wavelength of light

more than others. The majority of naturally occurring dyes are from plant sources roots, berries, bark, leaves and wood, fungi and lichens (Belter *et al.*, 2009).

Dyes have laser oscillation properties which find application in dye lasers or variable lasers. Their photoelectric conversion property also finds application in dye-sensitized solar cells. What the human eye perceives as the colour of a dye is the combination of the wavelengths not absorbed but reflected. Figure 2 shows an example of two different absorption spectra, both perceived as the very same nuance by the human eye (Cole *et al.*, 2000).

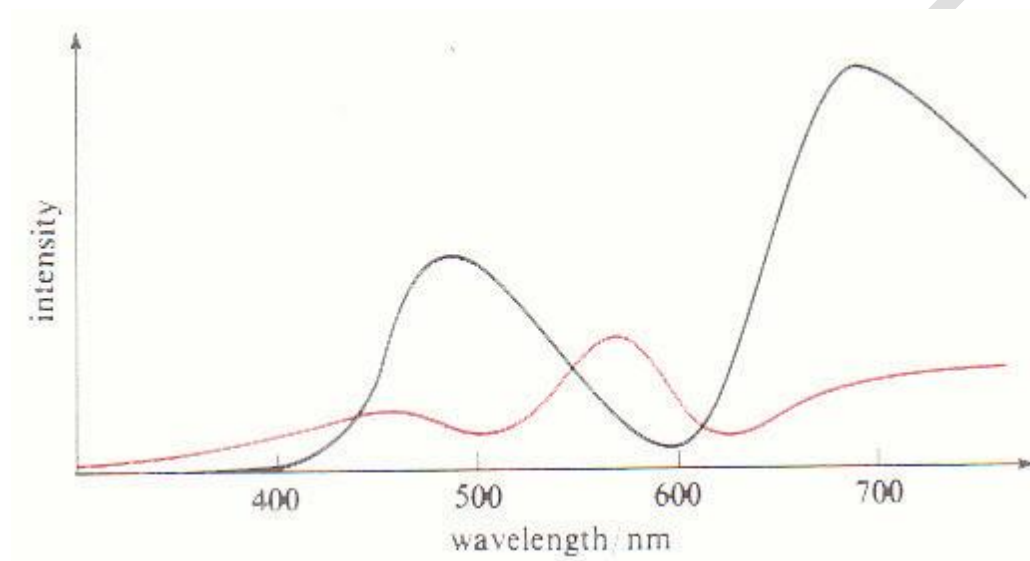

Figure 2: Two different absorption spectra, both perceived as the very same nuance by the human eye.

The light absorbed by the chromophore of a dye is of the complementary color of the apparent color of the dye. Chlorophyll, for example, absorbs mostly blue and red, reflecting green, and anthocyanins absorbs blue and green, giving us the perception of a red or violet color. Table 1. gives the relationship between absorbed light and reflected (or transmitted) light for part of the visible spectrum. The sunlight spectra contain much energy in the blue-green area which is the reason why the search for solar cell dyes is focused on green-absorbing red and purple dyes such as anthocyanins and betanins as well as the ruthenium dye (Harris, 2000).

Table 1: The relationship between Absorbed and Complementary Color (perceived) in the Visible Spectrum

Absorbed wavelengths/nm	Absorbed color	Complementary color
380-420	Violet	Green-yellow
420-440	Violet-blue	Yellow
440-470	Blue	Orange
470-500	Blue-Green	Red
500-520	Green	Purple
520-550	Yellow-green	Violet
550-580	Yellow	Violet-blue
580-620	Orange	Blue
620-680	Red	Blue-green
680-780	Purple	Green

Source: (Sigrid *et al.*, 2005)

Bioactivity

Solanum genus species like potatoes, tomatoes and aubergines consists of a vast array of secondary metabolites such as alkaloids, phenolic compounds, lectins and glycoalkaloids. The presence of pharmacologically active glycosidal alkaloids in Solanaceae has been known for centuries and in addition, spasmodic drug produced from this family were the only therapeutic agent alleviating Parkinsonism.

The glycosidal alkaloids in particular have been associated with antibiotic activity. Solanocapsine of solanum pseudocapsicum is antibacterial and the drug solanine from potatoes is

toxic to various species of fungi. In addition to antimicrobial activity some glycoalkaloid display antitumor effects as well.

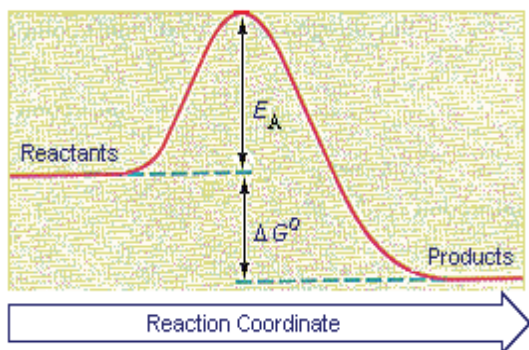

Figure 3: The energy relationship between reactants and products.

For any chemical process not occurring spontaneously, a certain amount of energy is required to be added to the system for the chemical reaction to be triggered. This energy quota is self-explaining called the activation energy; EA. Figure 3. illustrates the relationship: The horizontal axis represents reaction coordinates, which stand for the progress of the reaction.

The vertical axis represents the relative energies of the states. The natural tendency is to always strive for as low an energy level as possible. The energy difference between the energy levels of the reactants and the products is the Gibbs free energy, and it does not influence the reaction rate. The activation energy is in the figure represented as a barrier, which has to be overcome in order for the chemical reaction to take place. If the energy barrier had not been there, the reaction would have occurred spontaneously, but being there, it acts as a threshold, ensuring that not all colliding reactant molecules actually undergo the reaction. Only those colliding molecules with energy equal to or exceeding the activation energy EA will be able to perform the reaction (Steven, 1993). As both the frequency of collisions and the kinetic energy of the particles increase with increasing temperature, the temperature and the activation energy are both crucial to the reaction speed of any chemical process. The fraction of collisions rendering actual reactions increases exponentially with temperature (Steven, 1993). This is included in the Arrhenius equation:

$$K = Ae^{-\frac{EA}{RT}} \dots\dots\dots (2)$$

k is the rate constant, T is the temperature, R is the universal gas constant and A , called the frequency factor, includes the determining factor of molecular orientation. Taking the natural logarithm of equation (2), a linear equation is obtained:

$$\ln(K) = -\frac{E_A}{R}\left(\frac{1}{T}\right) + \ln(A) \quad (3)$$

Most rate constants obey the Arrhenius equation (Steven, 1993). Interlaced with the Arrhenius equation (2) is the rate of change of concentration of a reactant:

$$\frac{dc}{dt} = -k [c] \quad (4)$$

where c is the reactant concentration and t is the temporal variable. In the case of cyclic voltammetry, where the voltage is time-dependent, the concentration rate can also be considered with respect to voltage. The effect of the addition of platinum to the counter electrodes is that the activation energy barrier for the I^-/I_3^- ion pair of the electrolyte is essentially decreased to a level allowing for a much larger fraction of colliding reactant molecules to actually react. This is equivalent to a boost of the chemical reaction speed.

Results and Discussion

Electrochemical Impedance Spectroscopy (EIS)

EIS is a complementary technique to CV, while the latter represents only part of an electrochemical system, the result of the EIS measurements gives more complete description of the electrochemical system (Mamuru *et al.*, 2010) providing vital information about processes occurring at the electrode/electrolyte interface.

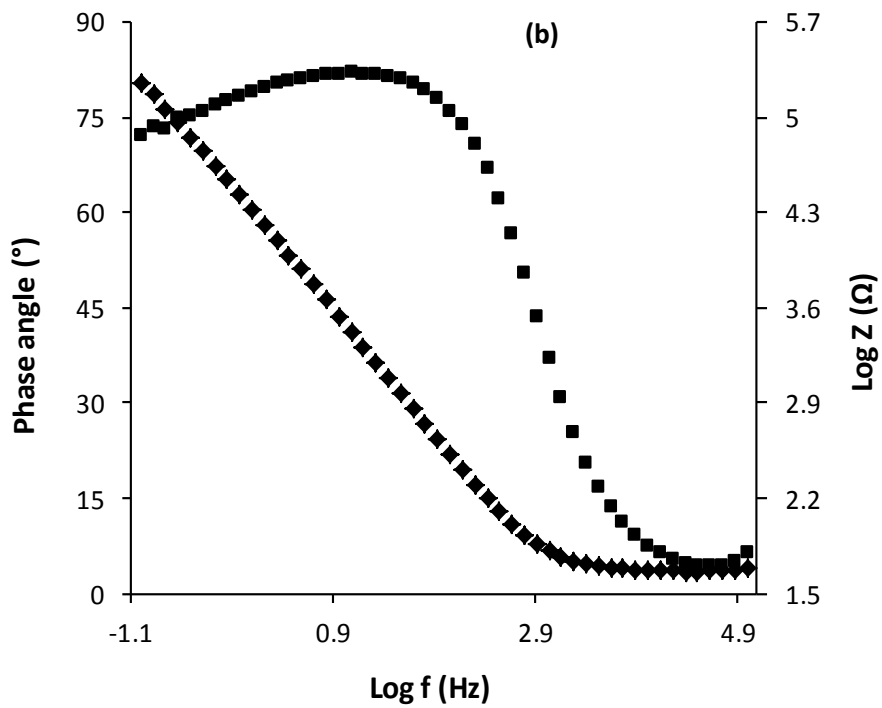
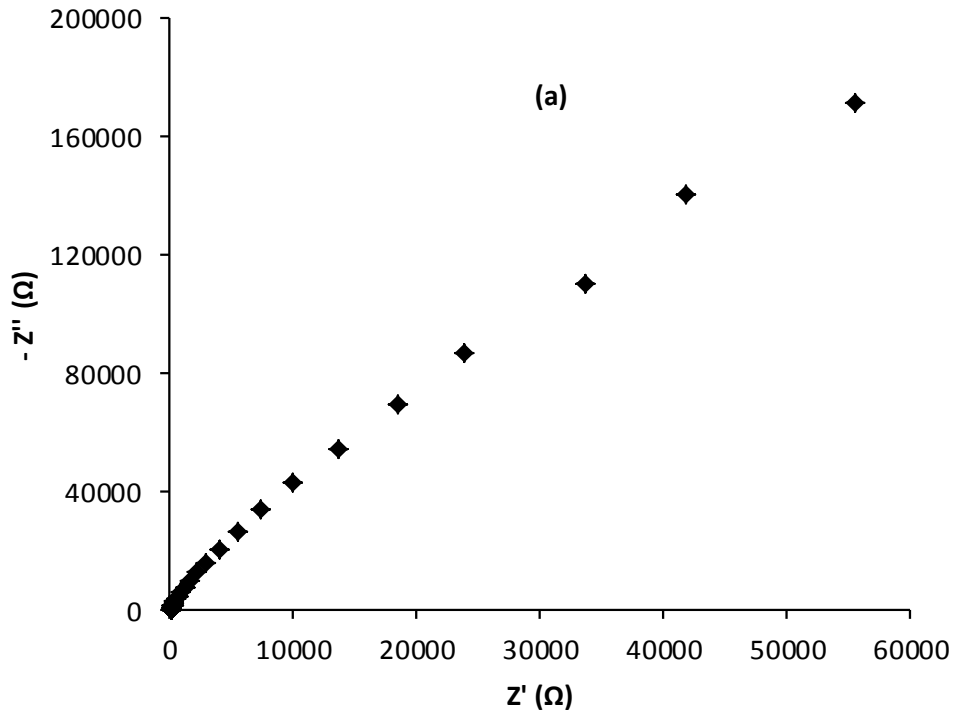

Figure 4: Nyquist and Bode plots of bare platinum (a, b) electrodes in 0.005 M $[\text{Fe}(\text{CN})_6]^{3-}/[\text{Fe}(\text{CN})_6]^{4-}$ 0.2 M NaOH solution.

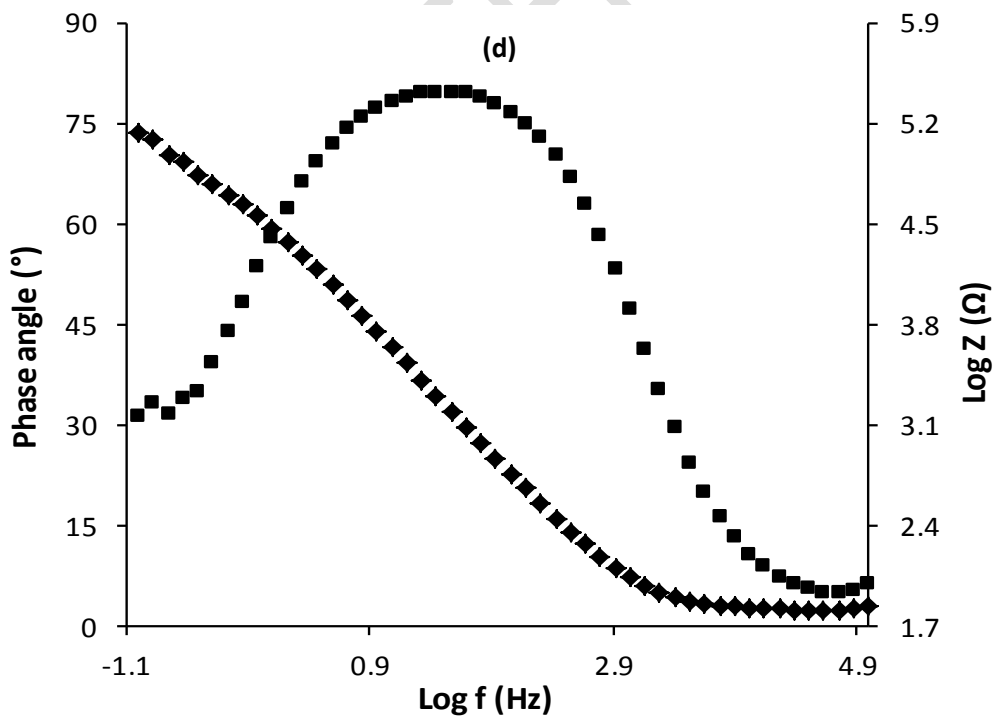
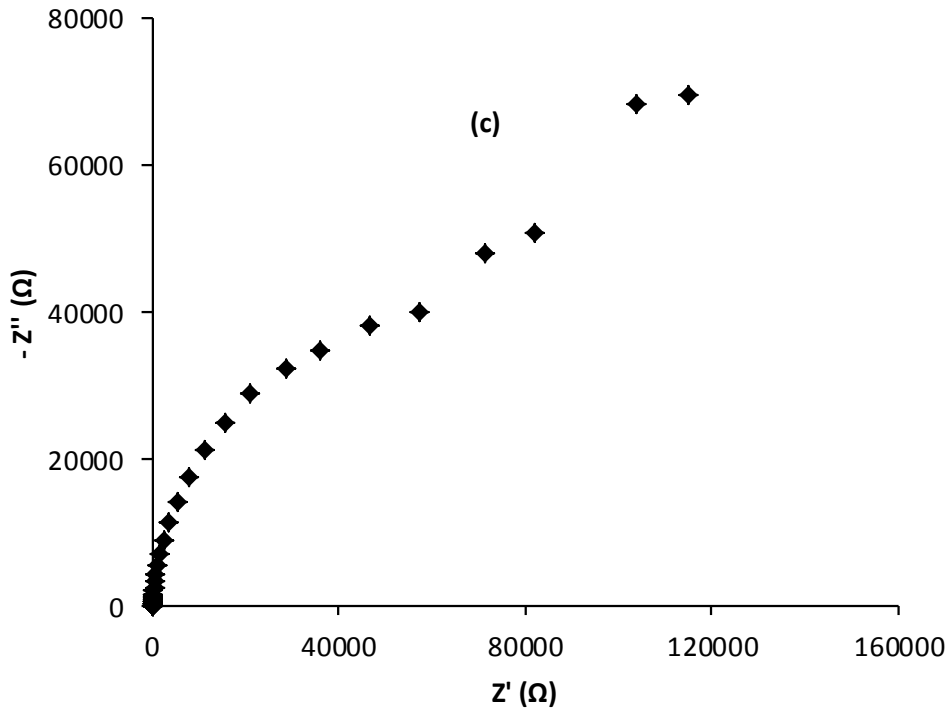

Figure 5: Nyquist and Bode plots of Pt/TiO₂/Dye (c, d) electrodes in 0.005 M $[\text{Fe}(\text{CN})_6]^{3-}/[\text{Fe}(\text{CN})_6]^{4-}$ 0.2 M NaOH solution.

Figs. 4. (a) and 5 (c) represents the Nyquist plots of the electrodes studied in 0.2 M NaOH containing 0.005 M $[\text{Fe}(\text{CN})_6]^{3-}/[\text{Fe}(\text{CN})_6]^{4-}$. The impedance spectra of the Pt/TiO₂/Dye electrode were satisfactorily fitted with the proposed equivalent electrical circuit (Fig. 4). The fitting parameters involve the solution resistance (R_s), electron transfer resistance (R_{ct}) and constant phase element (CPE). The apparent heterogeneous electron transfer rate constant (K_{app}) values of the electrodes were obtained using equation (4).

$$K_{app} = \frac{RT}{n^2 F^2 A R_{ct} c} \quad (4)$$

Where n is the number of electrons transferred.

A is the area of the electrode.

c is the concentration of $[\text{Fe}(\text{CN})_6]^{3-}$ and $[\text{Fe}(\text{CN})_6]^{4-}$ in mols cm^{-3} and they are equal.

R is the ideal gas constant.

T is the absolute temperature (K).

F is the Faraday constant.

The impedance of the CPE (Z_{CPE}) is defined as in equation (4.2).

$$Z_{CPE} = [Q(j\omega)^n]^{-1} \quad (5)$$

Where Q is the frequency independent constant related to the interface $j = \sqrt{-1}$,

ω is the radial frequency, the exponent n arises from the slope of $\log Z$ vs $\log f$ and has values of $-1 \leq n \leq 1$. If $n = 1$, CPE behaves as a pure capacitor, $n = -1$ CPE behaves as an inductor, $n = 0.5$ corresponds to Warburg impedance (W) which is associated with the domain of mass transport control arising from the diffusion of ions. From the Bode plots (Fig. 4. b and 4. d), the slopes of $\log Z$ vs $\log f$ at the mid frequency regions are less than the ideal -1.0 for pure capacitive behavior, which is indicative of pseudo-capacitive behavior. The data from the Bode plots (phase angle vs $\log f$) further confirms the absence of ideal capacitive behavior as the observed phase angles are less than the 90° expected of an ideal capacitive behavior.

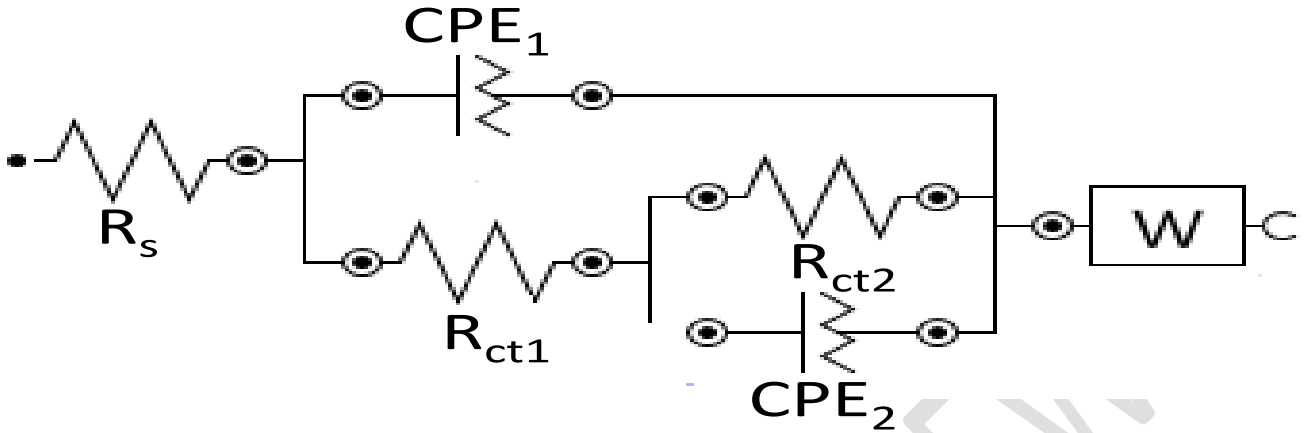

Fig. 6: Equivalent electrical circuit of Pt/TiO₂/Dye electrode

Table 2: Results of the impedance analysis for DSCs using four kinds of electrodes with *Solanum incanum* natural dye as sensitizer.

Electrode	Rs (Ω)	Rct (Ω)	W (Ω)	Circuit	χ^2
Pt	47.887	261.6	-	[R(C[RW])]	0.3198
Pt/Dye	47.337	524.8	6.522	[R(C[R(RQ)](RQ))]	0.0268
Pt/TiO ₂	48.024	2.383 E -5	-9459.2	[R(Q[R(RQ)])W]	0.0362
Pt/Dye/TiO ₂	60.097	-3456.6	1.5963 E +5	[R(Q[R(RQ)])W]	0.2611

CONCLUSION

The electrochemical properties of Pt/TiO₂/Dye modified electrode shows two pair of oxidation peaks at 256 and 474 mV which is ascribed to Fe³⁺/Fe²⁺, and a reduction peak of 210 mV which is ascribed to TiO₂/Dye. The high voltage is as a result of the impregnation of the dye on the TiO₂. Investigation into the internal resistance of the DSSC shows the dye can be strongly adsorbed to the surface of TiO₂, therefore Pt/TiO₂/Dye electrode transfers electron with very minimal resistance making the dye a good sensitizer material for DSSCs.

COMPETING INTERESTS DISCLAIMER:

Authors have declared that no competing interests exist. The products used for this research are commonly and predominantly use products in our area of research and country. There is absolutely no conflict of interest between the authors and producers of the products because we do not intend to use these products as an avenue for any litigation but for the advancement of knowledge. Also, the research was not funded by the producing company rather it was funded by personal efforts of the authors.

Reference

Atkins, P. W. and Friedman, R. S. (2000). *Molecular Quantum Mechanics*. Oxford University Press, 3rd edition.

Belter, M., Willibald, S. and Harold, C. (2009). Chemical stability and colorant properties of betaxanthin pigments from celosia argentea. *Journal of Agricultural and Food Chemistry*, 49:4429–4435.

Cole, J., Hill, R. and Roberts, D. (2000). *Chemical change and life - a source book in photochemistry*. The Open University Norway.

http://www.spie.org/app/Publications/magazines/oerarchive/august/solar_tech.html.

G24 Innovations (2011). Personalizing Solar Power, Solar Energy. <http://www.g24i.com/pages.uk-web.68.html>.

Sigr d, H. and Linn a, K. (2005). Plant Extract Sensitised Nanoporous Titanium Dioxide Thin Film Photoelectrochemical Cells. Department of Engineering Sciences, Uppsala University,  ngstr mlaboratoriet, L agerhyddsv gen 1, 751 21, Uppsala ISSN 1401-5765.

Steven S. Z. (1993). Fabrication of thin film dye sensitized solar cells. *Chemistry*. D. C. Heath and Company, 3rd Edition.