

DEVELOPMENT OF A SAWDUST FIRED FLUIDIZED BED REACTOR FOR SYNTHETIC GAS PRODUCTION

ABSTRACT

Aims: This research involves the development of a sawdust fired fluidized bed reactor for the production of synthetic gas for domestic cooking.

Study design: A sawdust fired fluidized bed reactor using AutoCAD inventor

Place and Duration of Study: Department of Mechanical Engineering, Federal University of Technology, Akure Ondo state Nigeria.

Methodology: The reactor consists of a hopper, rolled mild steel plate frame lined with clay which forms the frame, air distributor plate, and five radially spaced tuyeres. The reactor is fed with pelletized sawdust, retain heat within it and maintain a temperature of 50⁰ C at the external surface to minimize burns

Results: Air was forced into the plenum, after which the air distributor plate evenly distributed jets of air in the bed resulting in complete and incomplete combustion. Combustible gas was produced after 30 minutes and used to boil water.

Conclusion: The sawdust fired fluidized bed reactor is recommended for domestic household use.

Keywords: Sawdust; Fluidized; Designed; Fabrication; pyrolysis; cooking gas

1. INTRODUCTION (ARIAL, BOLD, 11 FONTS, LEFT ALIGNED, CAPS)

Fluidization is the process through which solid particles are transformed into a fluid-like suspension [1]. A system can be fluidized with the aid of forced air or steam. It results in efficient combustion due to the intimate mix of fuel and combustion agent.

Several methods and technologies exist to convert biomass into useable heat and energy products [2]. Two major pathways for its conversion are biochemical and thermochemical pathways as shown in Fig. 1. Each pathway has its advantages and drawbacks depending on the required application such as availability of raw material, conversion efficiency, etc.

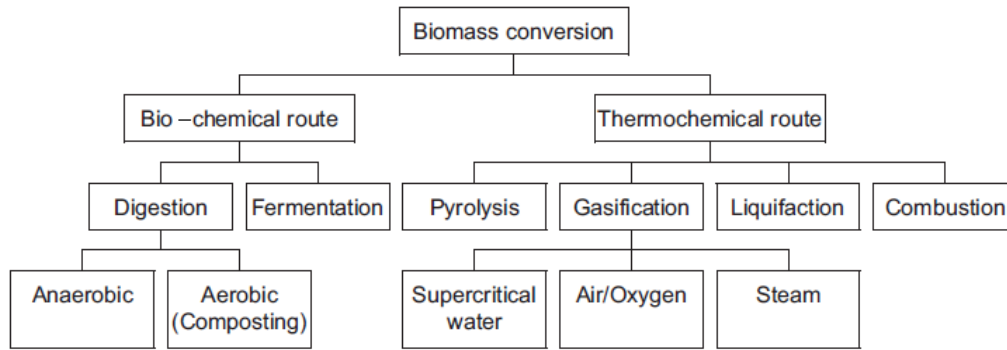

Fig. 1. Biomass Conversion routes [3].

Thirty-five (35%) of global energy is used up in residential functions [4]. Five major end functions have been identified as the main purposes for energy in the home which include cooking, electrical appliances, space heating, water heating and lighting. Cooking, space and water heating carry the highest quota and can be catered for using biomass sources [5]. Cooking alone represents the largest of these five end functions and a simple and efficient gasifier powered by a renewable energy source would be of tremendous value [5, 6]. Hence the need to develop a gasifier that could be used for cooking, water heating and space heating. The problem of energy and pollution is of immense importance to this present age [7]. Energy is one of the driving forces of the current societal living standards while pollution is one of its outcomes [8]. Efficient energy production with little or no devastating effect on our planet; remains an issue to be addressed, while exploitation of green energy sources is an offshoot of that quest. This work, therefore, intends to address national and global energy sustainability through green energy sources.

The study also intends to reduce the huge amount of sawdust that is generated daily in the society and regarded as waste to generate energy and provide a natural demand and supply pathway to ensure its consumption. It will also regulate and eventually minimize the effect of pollution caused by sawdust open-air incineration in saw-mills and mitigate its consequences on the environment. It will provide a simple means of harnessing the biomass energy contained in sawdust and present a blueprint for energy conservation and efficient management of biomass wastes

2. METHODOLOGY

The reactor consists of a hopper that feeds the reactor with sawdust pellets. A mild steel plate is rolled and welded to form the reactor. It is now lined with clay to successfully retain heat within it and maintain a temperature of 50⁰ C at the external surface to minimize burns. It is terminated at one end by the air distributor plate and the hopper at the opposite end. The air distributor plate provides an even distribution of the air. This creates a uniformly distributed film of air. A 3mm perforated mild steel plate also lined with clay is employed for this purpose. Five (5) radially spaced tuyeres are connected to the air distributor plate by a plenum. It supplies the system with air from the fan. A schematic diagram of the expected design is presented in Fig. 2

2.1 Design Analysis of Component Parts

2.1.1 Reactor Design

A gasifier suitable for a family of six is being considered. [9, 10], suggested that the energy requirement for cooking for 6 family members is 15.8 MJ/hr [11], established that the

expression for the fuel consumption rate (F.C.R.) in kg/hr as;

$$FCR = \frac{Q_n}{CV \times \eta_G} \quad (1)$$

Where; Q_n is the energy requirement (MJ/hr), CV is the calorific value of the feedstock in MJ and η_G is the gasifier efficiency.

The efficiency of similar gasifier designs has been established at 70% for purposes of design [11, 12].

With $Q_n = 15.8$ MJ/hr, the sawdust pellet calorific value experimentally determined as 16.36 MJ and η_G is the gasifier efficiency as 0.7. We have the fuel consumption rate calculated as FCR=1.38 kg/hr

2.1.2 Reactor Diameter (D)

According to Ojolo *et al.* [12] the reactor diameter can be calculated as follows;

$$D = \left(\frac{1.27 \times FCR}{SGR} \right)^{1/2} \quad (2)$$

Where D is the reactor diameter in meters, SGR is the specific gasification in kg/hr and FCR is the fuel consumption rate in kg/hr with FCR previously calculated as 1.38kg/hr and SGR for small scale gasifiers taken as 0.0325 m³/hr [12].

This gives the diameter as

$$D = 0.1803 \text{ m}$$

2.1.3 Minimum reactor height (H)

Belonio, [11] stated the following model for the minimum height of the reactor;

$$H = \frac{SGR \times T}{\rho_p} \quad (3)$$

Where T is the time required in hours for gasification, SGR is the specific gasification rate in kg and ρ_p is the density of the pellets.

According to the sustainable energy authority of Ireland [13], the density of wood pellets with a proximate analysis results similar to laboratory results gotten is 650kg/m³. If the gasifier time required for a family of six to heat is 2.5 hours [12] and for two families running adjacent kitchen units this would be 5 hours.

This gives us the minimum height of the reactor as

$$H = 0.41\text{m} = 410\text{mm}$$

The reactor employed is a modified double throat Imbert "hourglass" design which has its basis on the inverted V-hearth downdraft gasifier. A schematic view of the standard size proportions of a reactor is as shown in Fig. 2 where x is the throat diameter.

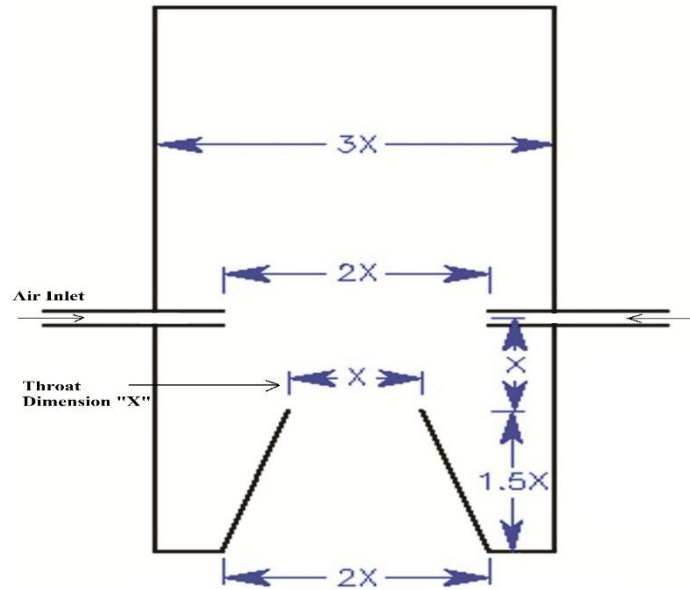

Fig. 2. Gasifier reactor size proportions, (AllPowerLabs, [14]).

The reactor diameter has been calculated as 180 mm and from the reactor proportions standard chart the maximum throat constrictor size is one-third of this. Hence,

Maximum throat diameter is = $180/3$ mm

This gives us a maximum throat diameter as 60 mm;

A compact design is required considering how it is intended to be used. Hence, the design parameter set is chosen from Appendix I using the maximum constrictor size of 60 mm as key. This refers to d_h

In order to prevent bridging problems, the inside diameter must be greater than 152.4 mm which refers to $3X$ in fig. 3 and determined to be 180 mm. The minimum length of a reactor with an inner diameter of 180 mm from Table 1 is 457.2mm

Table 1: Inside diameters for gasifier design

Inside Diameter (mm)	Minimum Length (mm)
50.8	406.4
101.6	406.4
152.4	406.4
177.8	457.2
203.2	508
228.6	558.8
254	609.6
279.4	660.4
304.8	711.2
330.2	762
355.6	812.8

Source: (AllPowerLabs, 2008).

The orientation of the tuyeres is changed from horizontal to vertical for design simplicity and ease of fabrication.

2.2 Nozzle Design

Using the maximum throat diameter of 60 mm which was determined in the reactor design, the nozzle parameters are as follows

Number of air jets: 5

The inner diameter of tuyeres: 7.5mm

These tuyeres are connected to a plenum which has a gas distributor plate at the opposite end to create and maintain an evenly distributed gas flow at the bottom of the bed

2.3 Hopper

A conical hopper is incorporated into the design to aid loading the biomass feedstock into the reactor. It is shown in Fig. 3

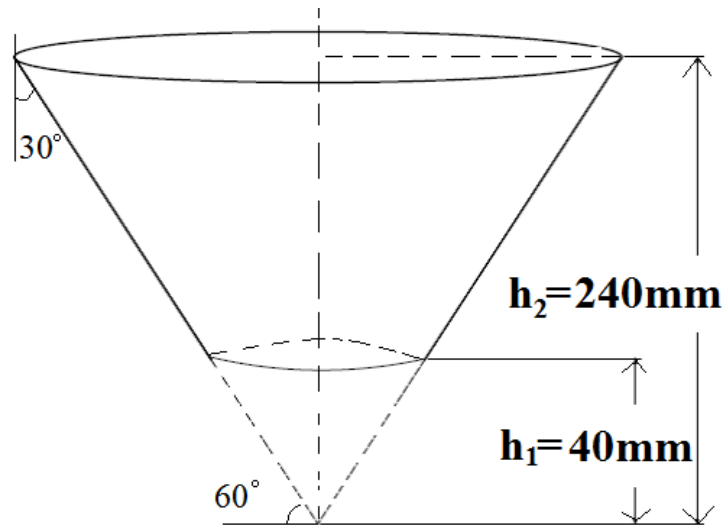

Fig. 3. Hopper Design

The volume of the hopper was determined with equation (4);

$$V = \pi r^2 \left(\frac{h_2}{3} - \frac{h_1}{3} \right) \quad (4)$$

Where r is the radius of the cone, h_1 and h_2 are the heights of the 2 cones as shown in Fig. 3 With $r = 0.115\text{m}$, $h_1 = 0.04\text{m}$ $h_2 = 0.24\text{m}$

This gives a volume of $V = 2.77 \times 10^{-3} \text{m}^3$

2.4 Air Distribution and Fan Requirement

2.4.1 Air Flow Rate (AFR);

The amount of air needed for gasification is also referred to as the airflow rate (AFR). [5, 11] described the model that can be used to calculate this as;

$$AFR = \frac{\varepsilon \times FCR \times SGR}{\rho_a} \quad (5)$$

Where ε is the equivalence ratio established by [12] as 0.3, FCR is the Fuel Consumption Rate earlier calculated as 1.38kh/hr, SGR is the specific gasification in kg/hr and ρ_a is the density of air established as 1.25Kg/m³.

This gives, AFR = 1.625m³/hr

2.4.2 Superficial Air Velocity (SA)

This is the velocity of air in the bed and described by Belonio, [5, 11] as the ratio of the Airflow rate to the Cross-sectional area of the reactor.

$$SA = \frac{AFR}{\text{Area of reactor}}$$
$$SA = \frac{4 \times AFR}{\pi D^2} \quad (6)$$

This gives the superficial velocity as 63.73m/hour or 1.77m/sec

A perforated plate is utilized as the distribution plate in the design and its parameters are as follows;

$$Re_t = \frac{d_t u_o \rho_g}{\mu} \quad (7)$$

Where Re_t is the Reynolds number, d_t is the outer diameter of pipe/tuyers inserted into the bed, which is 20mm. μ_o is the superficial velocity of inlet gas at the plenum which is calculated below. ρ_g is the density of the gas (air) which is 1.25 kg/m³ and μ is the viscosity of air at a temperature of 300K is 1.983 x 10⁻⁵ kg/m.s

u_o , is calculated from the exit of the 5 tuyers into the plenum. Each tuyer had been designed to have a diameter of 7.5mm an air blast velocity of 22.5m/s.

It is known that

$$Q = AV \quad (8)$$

Where Q is the volume flow rate, A is the cross-sectional area and V the velocity of fluid flow. Each tuyer has a cross-sectional area equal to

$$A = \frac{\pi d^2}{4} \quad (9)$$

$$A = 0.000442\text{m}^2$$

Consequently; $Q_{\text{tuyer}} = 0.0009945 \text{ m}^3/\text{s}$

For 5 tuyers, $Q_{\text{Total}} = 5 \times Q_{\text{tuyer}}$

$$Q_{\text{Total}} = 0.004973 \text{ m}^3/\text{s}$$

The total cross-sectional area of the distribution plate is

$$\begin{aligned} \text{Area}_{\text{Distribution Plate}} &= \text{Area}_{\text{Reactor}} & (10) \\ &= \frac{\pi D^2}{4} \\ &= 0.0226224 \text{ m}^2 \end{aligned}$$

Hence, $u_o = \frac{Q_{\text{Total}}}{\text{Area}_{\text{Distribution Plate}}} \quad u_o = 0.22 \text{ m/s}$

Also, $Re_t = \frac{d_t u_o \rho_g}{\mu}$

$$Re_t = 2666.67$$

2.5 Minimum thickness of Insulation required

i) Heat Transfer per meter length

To minimize heat loss, it is required that the temperature at the surface of the gasifier should be restricted to 50°C . With a typical reactor core temperature of 850°C

The heat loss through the pipe per unit length, Q_H is determined using equation 11 (Rajput, 2006)

$$Q_H/L = \frac{t_3 - t_1}{\ln\left(\frac{r_3}{r_1}\right) / 2\pi k} \quad (11)$$

Where,

$$\text{Width } t_3 = 850^\circ \text{C}, t_1 = 50^\circ \text{C}$$

There are four concentric cylinders of steel, clay and two envelopes of air, using equation (10).

Q_H is determined to be

$$Q_H = 3918 \text{ W}$$

This is for a length (in this case height of reactor) of 0.41m

Minimum thickness of insulation required = $r_2 - r_3$

Where; r_2 is the radius of the housing and r_3 is the radius of the internal shell.

$$r_2 = 0.209 \text{ m}$$

$$\begin{aligned} r_2 - r_3 &= 0.209 - 0.2 \\ &= 0.01 \text{ m} \\ &= 10 \text{ mm} \end{aligned}$$

The schematic drawing of the heat transfer Modelled design is shown in Fig. 4

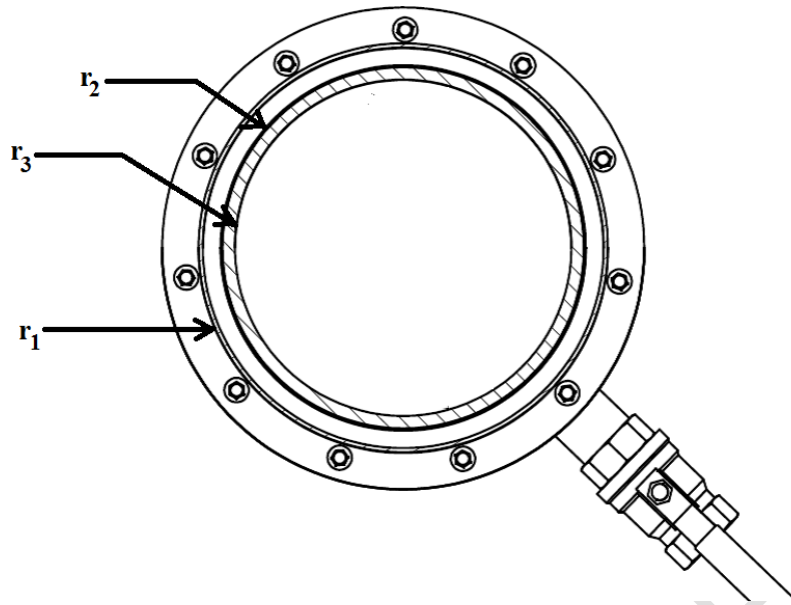

Fig..4. Schematic of Heat Transfer Model

Detailed Drawings

The detail drawings of the designed machine are as shown in Figures. 5 to 8

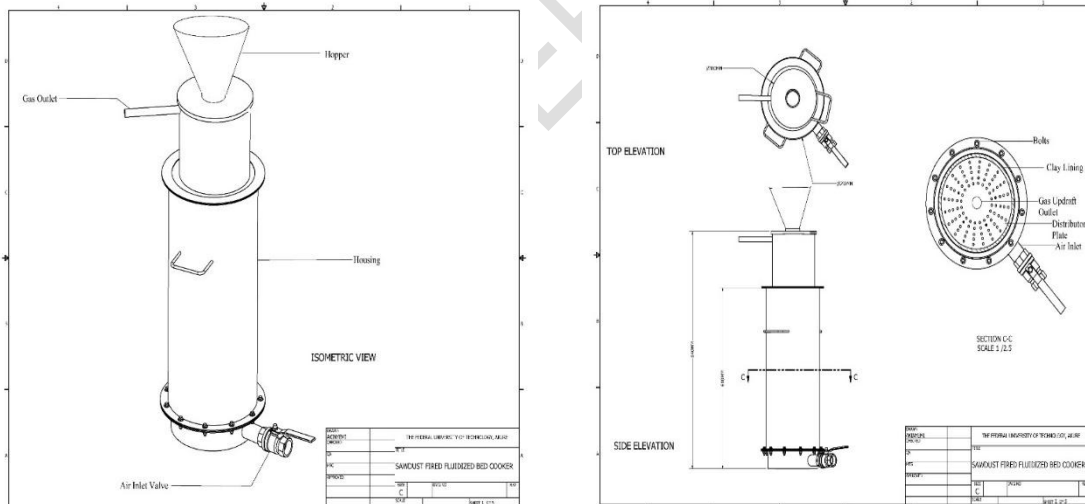

Fig. 5 a) Assembly Drawing of the Machine b) Sectional View of the gasifier

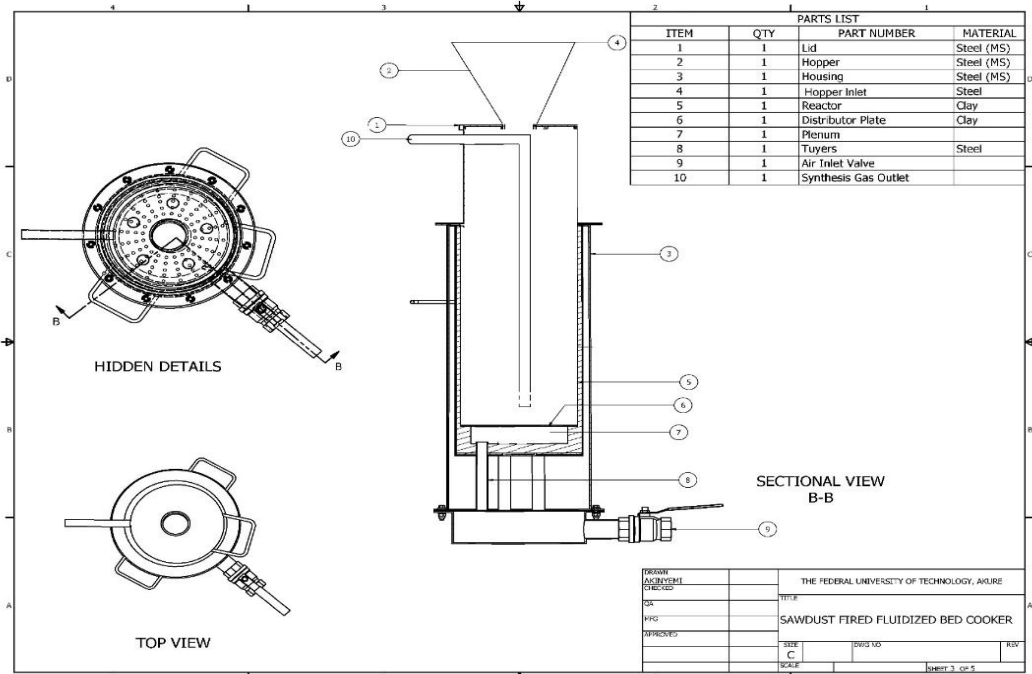

Fig. 6 Sectional View-II and Parts List

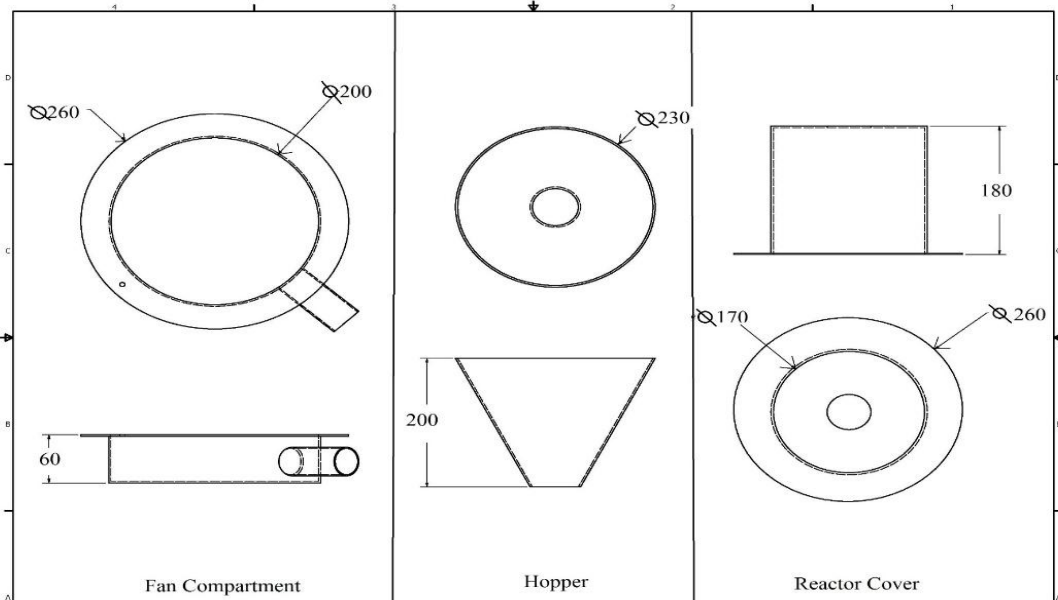

Fig. 7 Detailed Drawing of Components

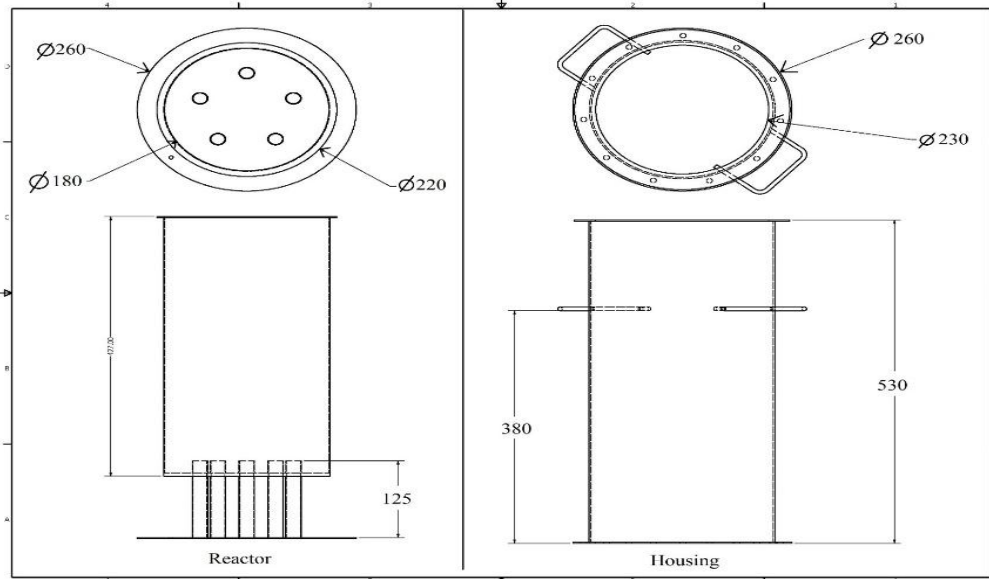

Fig. 8 Detailed Drawing of Components

UNDER PEER REVIEW

3. RESULTS

The fabricated machine is shown in plate 1. The combustible gas was seen to burn after 30 minutes of the pyrolysis reaction. The resulting gas was connected to cook tabletop burner and used to boil 1 liter of water. The average time for boiling water was evaluated. The water boils with A 20-minute Operation of the system is done in batches. The reactor side door is first opened and loaded with ignition material which is a mixture of the pellets and charcoal. It is manually ignited and fanned to red hot embers. This door is shut, and the pellets are loaded through the hopper. A digital k-band thermocouple is embedded in the reactor and used to measure temperatures that are displayed on the display module. Temperature readings are confirmed by a hand held infrared thermometer At about 600⁰ C ignitable gas was produced.



Fig. 9. Fabricated machine with displayed temperature

4. CONCLUSION

The sawdust fired fluidized bed reactor was developed and tested. Local materials were used for the parts of the reactor in order to reduce the cost of production without lowering the standard. The combustible gas from the machine was yielded after 30 minutes of pyrolysis. The reactor is connected to the gas tabletop and used for boiling water. The average time used to boil 1 liter of water is 20 minutes. The reactor is recommended for domestic use.

.”

CONSENT (WHERE EVER APPLICABLE)

All authors declare that 'written informed consent was obtained from the patient (or other approved parties) for publication of this case report and accompanying images. A copy of the written consent is available for review by the Editorial office/Chief Editor/Editorial Board members of this journal.'

REFERENCES

Reference to a journal:

For Published paper:

1. Kunii, D.; Levenspiel, O., Fluidization engineering. 2013: Elsevier.
2. Asadullah, M.; Miyazawa, T.; Ito, S.-i.; Kunimori, K.; Yamada, M.; Tomishige, K., Gasification of different biomasses in a dual-bed gasifier system combined with novel catalysts with high energy efficiency. Applied Catalysis A: General, 2004. 267(1-2), 95-102.
3. Basu, P., Biomass gasification, pyrolysis and torrefaction: practical design and theory. 2018: Academic press.
4. Daiglou, V.; Van Ruijven, B.J.; Van Vuuren, D.P., Model projections for household energy use in developing countries. Energy, 2012. 37(1), 601-615.
5. Bertani, R., Geothermal power generation in the world 2005–2010 update report. geothermics, 2012. 41, 1-29.
6. Lund, J.W.; Freeston, D.H.; Boyd, T.L., Direct utilization of geothermal energy 2010 worldwide review. Geothermics, 2011. 40(3), 159-180.
7. MacDonald, M.; Chadwick, M.; Aslanian, G., The environmental management of low-grade fuels. 2013: Routledge.
8. Blaschke, T.; Biberacher, M.; Gadocha, S.; Schardinger, I., 'Energy landscapes': Meeting energy demands and human aspirations. biomass and bioenergy, 2013. 55, 3-16.
9. P Pawar, R.; U Tekale, S.; U Shisodia, S.; T Totre, J.; J Domb, A., Biomedical applications of poly (lactic acid). Recent patents on regenerative medicine, 2014. 4(1), 40-51.
10. Panwar, N.; Rathore, N., Design and performance evaluation of a 5 kW producer gas stove. Biomass and bioenergy, 2008. 32(12), 1349-1352.
11. Belonio, A.T., Rice husk gas stove handbook. Appropriate Technology Center. Department of Agricultural Engineering and Environmental Management, College of Agriculture, Central Philippine University, Iloilo City, Philippines, 2005, 1-155.

12. Ojolo, S.; Abolarin, S.; Adegbenro, O., Development of a laboratory scale updraft gasifier. *International Journal of Manufacturing Systems*, 2012. 2(2), 21-42.
13. Ostman, B.; Tsantaridis, L., Innovative eco-efficient high fire performance wood products for demanding applications. *Wood Technology*, 2006.
14. Frederick, C.C., Evaluating the Effectiveness of the All Power Labs Power Pallet as a Training Tool for Biomass Gasification Education. 2013.

UNDER PEER REVIEW