

COVID-19 Pandemic: Laboratory Diagnostic Methods and Related Biosafety Regulations.

ABSTRACT

The repeated spread, loss of lives and melt down of the global economy as a result of the outbreak of Coronavirus Disease-2019 (COVID-19) caused by Severe Acute Respiratory Syndrome Coronavirus-2 (SARS-CoV-2), is posing a great challenge to the global health and economy. As of the first week of September, the disease has affected about 216 countries with nearly 900,000 deaths. In Nigeria, the total deaths recorded have exceeded one thousand. The rapid, early and accurate laboratory diagnosis of SARS-CoV-2 is one of the key roles in fighting against the disease. There is the problem of the insufficient sensitivity of a single means to detect the virus and the co-infection with other viruses, creating chance for a high false-negative result. In addition to molecular tests (which are the basis for confirmation of SARS-CoV-2) and Genomic sequencing, serological tests can be used as an additional test in other to boycott false negative results, and play an increasingly important role in understanding the epidemiology of the virus, identify people at risk of contracting the disease, and patients at risk for severe complications. This review will discuss the different laboratory diagnostic methods for SARS-CoV-2, the sample of choice and related biosafety regulations.

“Covid-19” “Biosafety”s: Coronavirus, Genomic sequencing, Nigeria, Severe Acute Respiratory Syndrome Coronavirus-2, serological tests.

1.0 INTRODUCTION

The continual spread, loss of life and melt down of the global economy caused by Coronavirus Disease-2019 (COVID-19) pandemic, is posing a great challenge to the global health and economy.

On 31 December 2019, a cluster of pneumonia cases of unknown aetiology was reported in Wuhan, Hubei Province, China, and on 9 January 2020, China Centre for Disease Control reported a novel coronavirus as the causative agent of this outbreak.^[1] The outbreak was declared a pandemic and a Public Health Emergency of International Concern (PHEIC) by the World Health Organization (WHO) on the 30th of January 2020, and is regarded as the third introduction of the highly pathogenic virus into the human population, following SARS-CoV in 2002-2003 and MERS-CoV in 2012.^[2, 3, 4] On 12 January 2020, WHO named the Coronavirus as the 2019-novel coronavirus (2019-nCoV) and on 11 February 2020, the Coronavirus Study Group (CSG) of the International Committee on Taxonomy of Viruses (ICTV) proposed to name the new coronavirus as SARS-CoV-2, the WHO officially named the disease as coronavirus disease 2019 (COVID-19) on the same date.^[5]

Coronaviruses are positive-sense RNA viruses with a single-stranded nucleic acid. They are spherical (80–160 nm), pleomorphic and enveloped viruses with a non-segmented genome (27–32 kb). Their genome is the largest discovered genome of RNA viruses, characterized by a 5'-end containing genes important for viral replication and pathogenesis in the host **cell**.^[6]

Medically important coronaviruses were first identified in the 1960s from a patient presented with mild colds, and are classified into four different phylogenetic **groups**; “**alphacoronaviruses** (α-CoV), betacoronaviruses (β-CoV), gammacoronaviruses (γ-CoV) and deltacoronaviruses (δ -CoV)”. The first three infect mammals, whereas the deltacoronaviruses infect avian species. However, all known human coronaviruses (HCoV) belong to the alphacoronavirus and betacoronaviruses.^[7]

SARS-COV-2 (**family: β-coronavirus, subfamily: Orthocoronavirinae, subgenus: sarbecovirus**). At present, there are Seven coronaviruses that can cause human **infections** but the common ones are 229E, NL63, OC43, and HKU1.^[6] The disease caused is characterized by some signs and symptoms ranging from common cold, fever, **diarrhoea, headache**, cough, the inability to taste or smell, dyspnoea and myalgia **etc**.^[7]

As of September 4th, 2020, a total of 216 countries and territories were affected, with 26,171,112 number of positive cases reported worldwide and over 865,154 deaths surpassing the combined number of cases and deaths of the previously occurred cases of coronaviruses (SARS-CoV and MERS-CoV).^[8]

In Nigeria, the total confirmed cases reported as of 4th September, 2020 is 54,743 (Male 64% and female 36%, most affected age group 31 - 40; 25%), with 1,051 confirmed fatalities, out of a total of 420,543 samples tested, covering the entire 37 States including the FCT.^[8, 9] Although the number of positive cases is declining in Nigeria, this might be attributed to the reduction in the number of tests carried out per day, which is linked to the shortage of available testing kits.^[10, 11, 12] However, the continued number of positive cases and deaths recorded daily, still poses a more serious threat to health and the nation's economy.

The rapid, early and accurate laboratory diagnosis of SARS-CoV-2 is one of the key roles in fighting against the disease.^[13] The much burden pose by SARS-CoV-2 is associated with the problem of the insufficient sensitivity of a single means to detect the virus along with the co-infection with other viruses, making it easier to be misdiagnosed because of false-negative results.^[14]

Virus detection based on culture provides much information for pathogenesis research, but due to the culture cycle is quite long, it is not recommended as a routine diagnostic procedure especially in severe cases.^[7] These necessitate the need for molecular assays. Nucleic acid tests can rapidly and sensitively identify pathogens in suspected or confirmed patients, the challenge is that huge amounts of genetic variants and mismatches of primers, probes, and target sequences can lead to the reduced detection performance and high false-negative results.^[15, 16] In addition to molecular tests and Genomic sequencing, serological tests can be used as an additional test to **avoid** false negative results. Serological test can be used as a tool in understanding the epidemiology and severity of the virus, identify people at risk of contracting the disease and the patients at risk for severe complications, to make an informed **decision**.^[17]

In Nigeria, there is very limited, or no research conducted on the various laboratory diagnostic methods for SARS-CoV-2 infections, and the various biosafety regulations attached to handling Coronaviruses. These might be related to the limited molecular diagnostic centres freely accessible to researchers and field scientist. These necessitated the need to enlighten Nigerians about the pandemic along with the vast array of the molecular tools, the samples of choice and biosafety containment facilities available for the diagnosis of the novel coronaviruses. **The molecular structure of SARS-CoV-2 and the Map of Nigeria showing the various state affected by COVID-19 are presented in (Figure 1 and 2).**

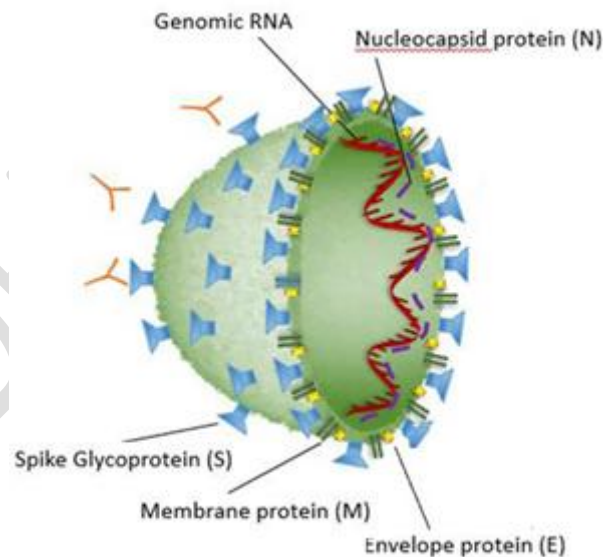

Figure 1: Molecular structure of SARS-CoV-2 showing the various components of the virus. Adapted from^[18]

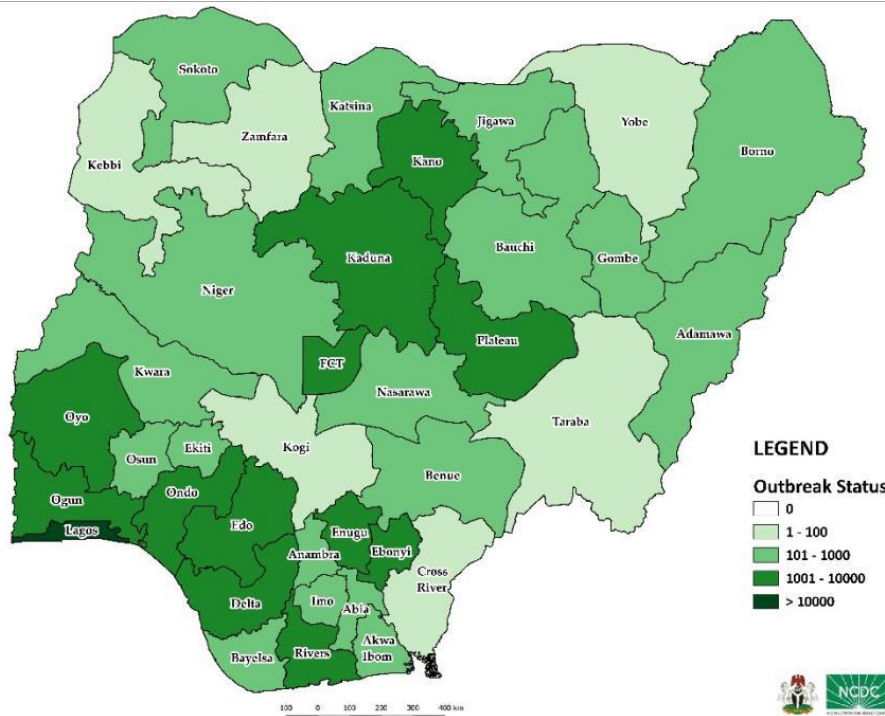

Figure 2: Map of Nigeria showing 36 states and FCT affected by COVID-19 as at September, 2020 [9]

2.0 CLINICAL SPECIMENS FOR SARS-CoV-2 Detection

Like other infectious diseases, appropriate specimen collection is the key step in the laboratory diagnosis of SARS-CoV-2 infections. Specimens include stool, blood, sputum, Broncho alveolar lavage fluid (BALF), serum, conjunctival swabs, oropharyngeal swab, rectal swab, throat swab, nasopharyngeal swabs and respiratory secretion. [16, 19] Moreover, SARS-CoV-2 has been frequently detected in urine and other non-respiratory specimens. To date, no virus has been detected in semen, female reproductive tract secretions, cerebrospinal fluid, joint fluid, peritoneal exudate, pericardial effusion, posterior fornix and many other samples. However, it is recommended that these samples be considered infectious, until research have proven otherwise. [16]

Once the specimens are collected, they are placed into separate sterile tubes, containing 2-3 mL of viral transport media, and must be kept refrigerated at 2-4°C for less than 4 days, or frozen at -70°C (or below) until testing is carried out. [7] Failure in appropriate pre-analytical treatment of specimens may generate a false negative result. Cold chain rules should strictly be observed from the point of sample collection to the evaluation stage.

Due to the fact that Angiotensin Converting Enzyme-2 (ACE2) is mainly distributed in alveolar type II epithelial cells, lower respiratory tract specimens (sputum, tracheal aspirates, BALF and nasopharyngeal swabs) may contain high viral RNA loads, therefore are considered high priority specimens, making it the most common specimens for SARS-CoV-2 analysis. [16, 19] The biological source for SARS-CoV-2 specimens, their various detection rates (ranging from 30-90%), collection and storage (ranging from -70°C to 2 °C) are summarised in Table 1 and 2.

Table 1: Biological Source and Various Detection Rate for SARS-CoV-2

Biological source	Detection rate
Bronchoalveolar lavage fluid	>90%
Saliva	~90%
Sputum	~70%
Nasopharyngeal and oropharyngeal swabs	~70%
Nasal swabs	~60%
Pharyngeal swabs	~30%
Stool	~30%
Throat washing	~30%

Adapted from Lippi^[7]**Table 2: Specimen Collection and Storage**

Specimen type	Collection materials	Storage temperature until testing in-country laboratory	Recommended temperature for shipment according to expected shipment time
Nasopharyngeal and oropharyngeal swab	Dacron or polyester flocked swabs*	2-8 °C	If ≤ 5 days: 2-8 °C, If > 5 days: -70 °C (dry ice).
Bronchoalveolar lavage	Sterile container *	2-8 °C	If ≤ 2 days: 2-8 °C, If > 2 days: -70 °C (dry ice).
(Endo) tracheal aspirate, nasopharyngeal or nasal wash/aspirate	Sterile container *	2-8 °C	If ≤ 2 days: 2-8 °C, If > 2 days: -70 °C (dry ice).
Sputum	Sterile container	2-8 °C	If ≤ 2 days: 2-8 °C, If > 2 days: -70 °C (dry ice).
Tissue from biopsy or autopsy including from lung	Sterile container with saline or VTM	2-8 °C	If ≤ 24 hours: 2-8 °C, If > 24 hours: -70 °C (dry ice).
Serum	Serum separator tubes (adults: collect 3-5 ml whole blood)	2-8 °C	If ≤ 5 days: 2-8 °C, If > 5 days: -70 °C (dry ice)
Whole blood	Collection tube	2-8 °C	If ≤ 5 days: 2-8 °C, If > 5 days: -70 °C (dry ice)
Stool	Stool container	2-8 °C	If ≤ 5 days: 2-8 °C, If > 5 days: -70 °C (dry ice)
Urine	Urine collection container	2-8 °C	If ≤ 5 days: 2-8 °C, If > 5 days: -70 °C (dry ice)

*For transport of samples for viral detection, viral transport medium (VTM) containing antifungal and antibiotic supplements is used. Repeated freezing and thawing of specimens is avoided. If VTM is not available sterile saline may be used in place of VTM (in such case, duration of sample storage at 2-8 °C may be different from what is indicated above). Apart from the collection materials listed in the table above, other equipment and materials may be required, such as: specimen collection bags, packaging coolers, transport containers, cold packs or dry ice, sterile blood-drawing equipment (e.g. needles, syringes and tubes), labels and permanent markers, PPE and other disinfectants etc. Adapted from WHO^[35]

3.0 DIAGNOSTIC TEST FOR SARS-COV-2 DETECTION

3.1 Nucleic acid tests for SARS-CoV-2 detection

Due to the changing nature of infectious disease and the need for a rapid analysis, extremely sensitive methods based on nucleic acid analyses were developed. These methods do not depend on an immune response to pathogens, but on detection of species-specific nucleic acid sequences in 16S rRNA genes or species-specific genes.^[20]

Nucleic acid tests are based on the principle of their highly specific base pairing with homologous strands.^[15] However, despite its fast and extremely sensitive nature, there is the large amounts of genetic variation in RNA viruses, mismatches of primers, probes, and target sequences, and may result in reduced detection performance and false-negative results.^[16] Hence, these necessitate the need to complement it with another serological test. The gene targets used to detect SARS-CoV-2 consist of spike (S), envelope (E), Nucleocapsid (N), RNA-dependent RNA polymerase (RdRp) and open reading frame1ab (ORF1ab) genes such as *ORF1a/b*, *ORF3a*, *ORF6*, *ORF7a/b*, *ORF8*, and *ORF10*, which encode accessory proteins, including the RNA-dependent RNA polymerase (RdRp).^[20]

The various nucleic acid test to be discussed here include SARS-COV-2 Detection by Real Time Reverse-Transcriptase Polymerase Chain Reaction (qRT-PCR), Loop-mediated isothermal amplification (LAMP) and CRISPR-based methods. The various coding genes present in the SARS-CoV-2 genome along with their varying sizes are illustrated in (Figure 3 and 4).

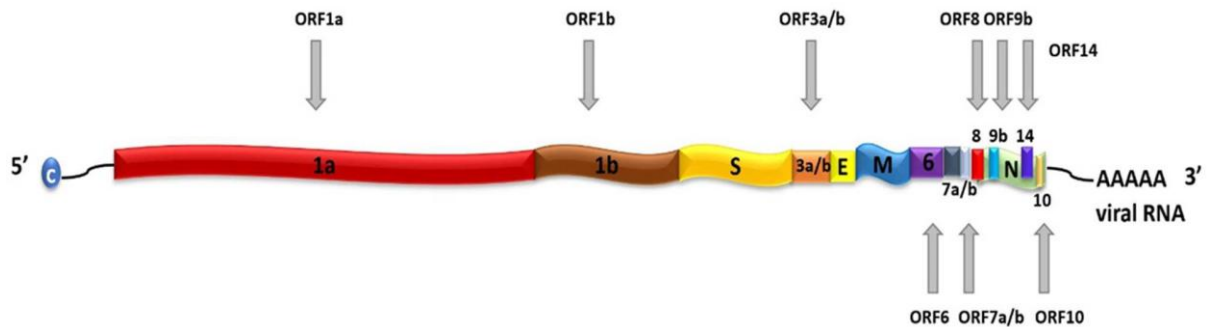

Figure 3: | Schematic representation of SARS-CoV-2 genome. showing the coding genes: ORF1a, ORF1b, Spike (S), ORF3a, ORF3b, Envelope (E), Membrane (M), ORF6, ORF7a, ORF7b, ORF8, ORF9b, ORF14, Nucleocapsid (N), and ORF10. It depicts the positive-sense and a positive-stranded mRNA genome with a 5' capped mRNA sequence (C) and a 3' poly-A tail.^[18]

3.1.1 SARS-COV-2 Detection by Real Time Reverse-Transcriptase Polymerase Chain Reaction (qRT-PCR)

SARS-CoV-2 qRT-PCR test allows for early detection of low viral titres, this is due to the anticipated limit of detection of <10 copies/reaction.^[21] SARS-CoV-2 genome contains around 30,000 nucleotides and 15 genes. Several of these genes have been used as primer/probe targets for diagnostic reverse-transcription polymerase chain reaction (RT-PCR) assays, including the E, N, RdRp, non-structural protein (nsp10), and nsp14 exoribonuclease genes.^[10, 21]

RT-PCR detects the genetic material of SARS-CoV-2 to identify the virus and quantify viral load, with a high sensitivity up to 95%.^[22] Gene amplification indicates a positive result for the presence of SARS-CoV-2 RNA and should correlate with clinical observations, patient history and epidemiological information. In PCR-based assays, sequence variants can result in reduced recognition by the individual primer-probe sets used, however the proofreading function of Nsp14 limits the rate of nucleotide miss-incorporation.^[18] The main disadvantages of RT-PCR based assays for SARS-CoV-2 detection, is that the cross-reactivity of primers with nucleic acids, which may arise from co-infection with other viruses or bacteria, may lead to the detection of a different agent which may not be the actual cause of the disease. To reduce the high chances of false positive results, there is the need for Matching of the SARS-CoV-2 RT-PCR primers and probes using reliable libraries (e.g., BLAST), to ensure the absence of homology with other viruses or microorganisms such as *Candida albicans* and *Staphylococcus aureus*. A negative patient sample can be used to identify errors that are associated with the contamination of reagents, especially due to the high volume of testing encountered during a pandemic.^[18, 22]

The accuracy and reliability of RT-PCR for the diagnoses of SARS-CoV-2 can further be influenced by the procedures used for collecting, transporting and storing the specimens, as well as from concomitant antiviral therapy.^[7] Strict adherence to all the protocols for sample collection is required for a valid result.

As the gold standard test for SARS-CoV-2 identification, RT-PCR (qRT-PCR) is the routine confirmatory test recommended by WHO. However, due to its time-consuming process, the requirements of expensive equipment and biosafety conditions, this test is not suitable for point-of-care diagnosis. Point-of-care tests are not only suitable for clinical laboratories, but also can be performed by trained non-laboratory personnel in patient care facilities, bringing closer the diagnostic test for SARS-CoV-2 closer to patient.^[15]

A comparison of different nucleic acid amplification of SARS-CoV-2, including Lab-based tests and point-of-care tests, is shown in (Table 3).

Table 3: RT-PCR Tests/Primers for SARS-CoV-2 in Different Institutions

Institute	Gene target	Probe (5'-3')	Forward primer (5'-3')	Reverse primer (5'-3')
China CDC	ORF1ab gene	FAM-CCGTCTGCGGTATGTGGA AAGGTTATGG-BHQ1	CCCTGTGGGTTT TACACTTAA	ACGATTGTGCATC AGCTGA
	N gene	FAM-TTGCTGCTGCTTGACAG A TT-TAMRA	GGGGA ACTTCTC CTGCTAGAAT	CAGACATTTTGCT CTCAAGCTG
US CDC	N1 target	FAM-ACCCCGCATTAC GTT TGGTGGACC-BHQ1	GAC CCC AAA ATC AGC GAA AT	TCT GGT TAC TGC CAG TTG AAT CTG
	N2 target	FAM-ACAATTTGCCCCAGCG C TTCAG-BHQ1	TTA CAA ACA TTG GCC GCA AA	GCG CGA CAT TCC GAA GAA'
	N3 target	FAM-AYCACATTGGCACCCGC A ATCCTG-BHQ1	GGG AGC CTT GAA TAC ACC AAA A	TGT AGC ACG ATT GCA GCA TTG
France Pasteur Institute	RdRP1 target	HEX-AGATGTCTTGTGCTGCC G GTA-BHQ1	ATGAGCTTAGTC CTGTTG	CTCCCTTTGTTGT GTTGT
	RdRP2 target	FAM-TCATACAAACCACGCCA G G-BHQ1	GGTAACTGGTAT GATTTTCG	CTGGTCAAGGTTA ATATAGG
Japan National Institute of Infectious Disease	N gene	FAM-ATGTCGCGCATTGGCAT G GA-BHQ	AAATTTTGGGGA CCAGGAAC	TGGCAGCTGTGTA GGTCAAC
Germany Charité	RdRP gene	FAM-CAGGTGGAACCTCATCA G GAGATGC-BBQ	GTGARATGGTCA TGTGTGGCGG	CARATGTAAASA CACTATTAGCATA
	E gene	FAM-ACACTAGCCATCCTTACT GCGCTTCG-BBQ	ACAGGTACGTTA ATAGTTAATAGCG T	ATATTGCAGCAGT ACGCACACA
Thailand National Institute of Health	N gene	FAM-CAACTGGCAGTAACCA-BQH1	CGTTTGGTGGAC CCTCAGAT-	CCCCACTGCGTTC TCCATT
Hong Kong University	ORF1b-nsp14 gene	FAM-TAGTTGTGATGCWATCA TGACTAG-TAMRA	TGGGGYTTTACR GGTAACCT	AACRCGCTTAACA AAGCACTC
	N gene	FAM-GCAAATTGTGCAATTTGC GG-TAMRA	TAATCAGACAAG GAACTGATTA	CGAAGGTGTGACT TCCATG

3.1.2 Loop-Mediated Isothermal Amplification (LAMP)

Loop-mediated isothermal amplification (LAMP) is a user-friendly technique and can provide reliable, sensitive and specific results in lesser time as compared to other conventional techniques. These made its applications in microbial detection and disease diagnosis quite popular.^[16] LAMP can be used to amplify any genomic material with high efficiency and in shorter time by incorporating isothermal methods using a polymerase with strand-displacement activity that separates the strand that is annealed to the target sequence for detection. Amplified gene products can be detected by photometry. Isothermal nucleic acid amplification, been a novel technique, is utilised in several commercial molecular diagnostic platforms and is considered the fastest available molecular laboratory and point-of-care test for the detection of novel SARS-CoV-2.^[15, 18]

LAMP employs the synthesis of target DNA at constant temperature of 60–65⁰C using the enzyme (DNA polymerase) which have a strand displacement activity instead of heat denaturation as in other PCR techniques.^[15] This technique has the advantage of requiring only single constant temperature, and thus eliminating the need of thermocycler and high-power consumption.^[15, 16]

3.1.3 Clustered Regularly Interspaced Short Palindromic Repeats (CRISPR) Based Methods

The CRISPR-based nucleic acid detection methods employs the use of recombinase polymerase amplification in combination with CRISPR-Cas enzymology for specific recognition of targeted DNA or RNA sequences.^[18] CRISPR have also been developed for point of care nucleic acid detection, such as the DETECTR or SHERLOCK (Specific High-Sensitivity Enzymatic Reporter unlocking) and can be used by particularly low-resource countries to checkmate the transmission of SARS-CoV-2 especially in areas at greatest risk of transmission, such as Community hospitals, schools, airports and car parks, etc.^[18]

The CRISPR/Cas13a system is a CRISPR-RNA (crRNA) guided detection method, that is designed specifically for RNA and is used for SARS-CoV-2 detection. The Cas13a enzyme binds targeted RNAs in a sequence-specific manner followed by non-specific trans-endonuclease cleavage of non-targeted RNA for signal amplification and nucleic acid detection.^[22] The SHERLOCK is made in order to obtain a more sensitive result and is obtained by pairing the Cas13a assay with target nucleic acid amplification, using an isothermal exponential amplification technique, most commonly.^[18, 22]

The endonuclease activity of purified Cas13a uses crRNA targeting sequences in the S gene and ORF1ab in SARS-CoV-2 RNA. Target site-recognition activates trans-cleavage of reporter probes which result in an increased fluorescence output signals, thereby confirming the presence of viral RNA.^[18] This method can sensitively detect as low as 10 copies/ μ L for synthetic RNA or in vitro viral RNA transcripts.^[17]

The results of the CRISPR-based methods can be analysed by fluorescent, colorimetric, lateral flow strip and other readout approaches in 60 min with a setup time of less than 15 min.^[22]

Studies conducted to compare the workflow of CRISPR point of care methods (SHERLOCK or DETECTR) and RT-qPCR which were all approved and recommended by CDC and WHO for SARS-CoV-2 detection suggest that RT-qPCR is more sensitive than the CRISPR-based assay, just that the CRISPR based assay is more convenient and timesaving than RT-qPCR, thereby offering immense hope for future disease control.^[23]

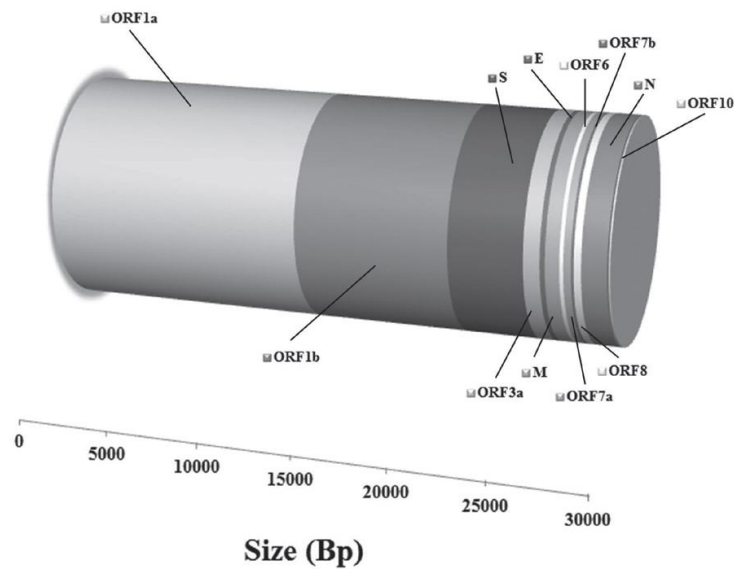

Figure 4: Gene structure for SARS-CoV-2. [7]

Table 4: Genome and protein size for SARS-CoV-2.

Gene	Genomic Size (bp)	Protein size (aa)
ORF1a	13542	4405
ORF1b	8021	2691
S	3821	1273
ORF3a	836	275
E	252	75
M	719	222
ORF6	196	61
ORF7a	372	121
ORF7b	128	34
ORF8	372	121
N	1274	419
ORF10	141	38

(Adapted from Lippi)^[7]

3.2 Serological Testing

Serological tests are diagnostic procedures that identify the presence of an immune response against an infectious agent. Serological test does not replace the identification of viral RNA for etiological diagnosis of SARS-CoV-2; but can be used for establishing as to whether individuals have been infected by the virus or have developed an immune response. SARS-CoV-2 serological test is used mostly for epidemiological and surveillance purposes.^[24, 25]

Antibodies detected from SARS-CoV-2 patients are mainly divided into IgA, IgG and IgM. Most of SARS-CoV-2 specific antibodies for both IgM and IgA become positive after 3-5 days following the onset of symptoms, whilst it is delayed to 10-18 days for IgG. The first immunoglobulin produced in response to an infection is the IgM and is primarily detected during the early onset of disease. IgG is the most abundant immunoglobulin that is produced in response to an antigen (7–25 days) and is maintained in the body after initial exposure which may have a protective role for acquired immunity. The IgA plays a crucial role in the immune function of mucous membranes.^[2, 7]

Antibody test is appropriate for convalescence phase of the infection in case of a symptomatic infection, but the presence of rheumatoid factor, non-specific IgM and other interfering substances present in the blood sample contributes to a very high false-positive rate. In the case of negative Nucleic Acid Amplification Test (NAAT), SARS-CoV-2 specific IgM / IgG antibody can be used as a diagnostic standard. The principle is that more than twice dynamic detections are required.^[14]

Serological test encompasses the identification and measurement of different classes of immunoglobulins (IgA, IgM, IgG) against SARS-CoV-2, but can also be used for establishing whether a person has been

infected, and has then developed antibodies which, if possessing neutralizing effects, may prevent future re-infection.^[7]

One of the major unsettled issues to the emergence of SARS-CoV-2 infections, is establishing whether anti-SARS-CoV-2 antibodies shall be considered effective to neutralize virulence, as well as their persistence in blood. However, Haveri^[26] shows that human anti-SARS-CoV-2 antibodies possess neutralizing effect as it specifically targets Nucleocapsid and spike proteins. These findings have been confirmed in a subsequent study, by Lippi^[2] who showed that the rate of anti-SARS-CoV-2 antibody positivity up to two weeks after the onset of symptoms is as high as 100% for both IgA and IgG, whilst IgM could only be measured in 60% of SARS-CoV-2 patients after the same period. Similar studies reveal that positivity for anti-SARS-CoV-2 IgG and IgM antibodies is 95% and 50% respectively.^[27] Fang^[17] reported that by 3 weeks, nearly all patients have seroconverted, and the antibodies persist for at least 2 months, with IgG showing greater persistence. More hope arises, due to the fact that earlier findings on the former and similar coronavirus disease SARS, reveal that the titre of anti-SARS-CoV-1 neutralizing antibodies was found to be stably high for 16 months after infection, but progressively declined afterwards, falling to 50-75% after 4 years and ~10% after 6 years, respectively.^[28]

3.2.1 Enzyme-Linked Immunosorbent Assay (ELISA)

This is one of the most widely used serological test for identifying antibodies in patient blood sample or nasopharyngeal swabs. This test involves the linking of various labelled enzymes to either antigens or antibodies. The basic methods used are the double antibody sandwich assay and the indirect immunosorbent assay.

a) The double Antibody Sandwich Assay (DASA): This is used for the detection of SARS-CoV-2 antigens and involves the placement of specific antibody in wells of a microtiter plate which is absorbed onto the walls, thereby coating and sensitizing the plate. To each well in the plate, a test antigen is added. If the antigen reacts with the antibody, the antigen is retained when the wall is washed to remove unbound antigen. An antibody specific for the antigen (usually an antibody enzyme conjugate) is then added to each well. The final complex is formed of an outer antibody-enzyme, middle antigen and inner antibody that is layered (Ab-Ag-Ab) sandwich. A substrate that the enzyme will convert to a coloured product is then added, and any resulting product is quantitatively measured by optical density scanning of the plate. A positive test is noted, if the antigen has reacted with the absorbed antibodies in the first step. A negative test is noted when the antigen is not recognised by the absorbed antibody, because the unattached antigen has been washed away and no antibody-enzyme is bound. Several of kits are available for detection of SARS-CoV-2 and many different viruses.^[16, 24]

b) The Indirect Immunosorbent Assay (IIA): unlike the DASA which detects antigens, IIA is used to detects SARS-CoV-2 antibodies. It involves the incubation of SARS-CoV-2 antigens in a buffered solution contained in the wells of a microtiter plate, where the antigens are absorbed onto the walls of the wells. Free antigen is washed away. Test antiserum is added, and if SARS-CoV-2 specific antibody is present, it binds to the antigen. Unbound antibody is washed away. An anti-antibody that has been covalently coupled to an enzyme, such as horseradish peroxidase, is added next. The antibody-enzyme complex (the conjugate) binds to the test antibody, and after unbound conjugate is washed away, the attached ligand is visualised by the addition of chromogen (a colourless substrate acted on by the enzyme portion of the ligand) to produce a coloured product. The amount of the SARS-CoV-2 antibody is quantified in the same way as an antigen in the double antibody sandwich method.^[16]

3.2.2 The performance of various serological detection tests

Due to current advances in disease diagnosis, there has been a marked increase in number of sensitivity and specificity of many serological tests. These results in a better understanding of immunologic diseases and the development of many novel and rapid diagnostic methods. The performance comparison analysis of various serological detection tests were described in (%), along with their detected antibodies, specificity and sensitivity are summarised in (Table 5).

Table 5: The performance comparison analysis of serological detection tests

Tests	Detected antibodies	Specificity	Sensitivity (0-7d)	Sensitivity (8-14d)	Sensitivity (>=15d)	Total Sensitivity
Euroimmun (ELISA)	IgA,	86.1%	65.5%	87.09%	93.93%	83.6%
	IgG,	98.6%	17.2%	66.12%	90.9%	61.7%

	IgA or IgG	87.5%	65.5%	88.7%	93.93%	84.4%
Maglumi™ (CLIA)	IgM	100.0%	14.3%	64.51%	87.5%	58.7%
	IgG	100.0%	7.1%	54.8%	87.5%	53.2%
	IgM or IgG	100.0%	17.9%	69.4%	93.8%	64.3%
Alltest (LFA)	IgM,	100.0%	21.1%	93.0%	60.0%	28.9%
	IgG,	100.0%	21.1%	33.3%	86.7%	60.0%
	IgM or IgG	100.0%	26.3%	42.9%	93.3%	64.4%
Clungene (LFA)	IgM,	91.3%	16.2%	42.3%	55.3%	39.2%
	IgG,	98.1%	29.7%	60.3%	97.4%	62.1%
	IgM or IgG,	90.3%	35.1%	64.1%	97.4%	65.4%
	IgM and IgG	99.0%	10.8%	38.5%	55.3%	35.9%
OrientGene (LFA)	IgM,	95.1%	40.5%	75.6%	97.4%	72.5%
	IgG,	93.2%	40.5%	69.2%	92.1%	68.0%
	IgM or IgG	91.3%	46.0%	80.8%	97.4%	76.5%
	IgM and IgG	97.1%	35.1%	64.1%	92.1%	64.1%
VivaDiag (LFA)	IgM,	100.0%	35.1%	64.1%	97.4%	65.4%
	IgG,	99.0%	35.1%	60.3%	97.7%	62.8%
	IgM or IgG	99.0%	35.1%	64.1%	97.4%	65.4%
	IgM and IgG	100.0%	35.1%	60.3%	94.7%	62.8%
StrongStep (LFA)	IgM,	99.0%	10.8%	33.3%	50.0%	32.0%
	IgG,	99.0%	32.4%	64.1%	97.4%	64.7%
	IgM or IgG	98.1%	35.1%	66.7%	97.4%	66.7%
	IgM and IgG	100.0%	8.1%	30.8%	50.0%	30.1%
Dynamiker (LFA)	IgM,	95.1%	46.0%	66.7%	97.4%	69.3%
	IgG,	99.0%	27.0%	61.5%	94.7%	61.4%
	IgM or IgG	95.2%	46.0%	66.7%	97.4%	69.3%
	IgM and IgG	99.0%	27.0%	61.5%	94.7%	61.4%
Multi-G (LFA)	IgM,	91.3%	27.0%	44.9%	57.9%	43.8%
	IgG,	97.1%	29.7%	65.4%	97.4%	64.7%
	IgM or IgG	88.3%	43.2%	71.8%	97.4%	71.2%
	IgM and IgG	100.0%	13.5%	38.5%	57.9%	37.3%
Prima (LFA)	IgM,	93.2%	43.2%	56.4%	68.4%	56.2%
	IgG,	90.3%	40.5%	71.8%	100.0%	71.2%
	IgM or IgG	85.4%	56.8%	79.5%	100.0%	79.1%
	IgM and IgG	98.1%	27.0%	48.7%	68.4%	48.4%
pGOLD assay (Nano- Plasmonic Platform)	IgM,	99.8%	43.8%	66.7%	100.0%	77.1%
	IgG,	99.8%	12.5%	47.6%	100.0%	64.3%
	IgM and IgG	99.8%	43.8%	66.7%	100.0%	77.1%

Adapted from Li^[16]

3.3 SARS-CoV-2 Genomic sequencing.

Genomic sequencing of viruses employs the use of next-generation sequencing (NGS) otherwise known as high-throughput sequencing (HTS). It is one of the most powerful tools for analysing virus evolution, and genetic association to diseases, tracking outbreaks and development of new therapies and vaccines.

^[16] This method can be used to determine the genomic sequence of more than a million base pairs in a

single experiment, with high precision and traceability even in a single patient, while other routine surveillance techniques could not do it with that much precision.^[25] NGS helps not only in the discovery of novel viral strains on large scale but also provides very rapid detection of unknown pathogens, and the detection of mutation or recombination in their genomes.^[15] To better understand the spread of SARS-CoV-2 pandemic and design better interventions, whole genome sequencing of the virus from a range of clinical presentations of the disease in different parts of the world must occur. These can be used to inform molecular epidemiology studies and monitor for viral genome mutations that might affect the performance of medical countermeasures, including diagnostic tests.^[25, 29]

As of August 2020, many public-access databases for deposition of SARS-CoV-2 genetic sequence data were released on public databases. These includes; NCBI GenBank, China National Gene Bank Database (CNCBdb), the Sequence Read Archive of the US National Centre for Biotechnology and Global initiative on sharing all influenza data.^[16, 29, 30]

The various next generation sequencing methods of SARS-CoV-2 presently in use include Nanopore targeted sequencing (NTS), hybrid capture-based sequencing, amplicon-based next-generation sequencing and metatranscriptomics sequencing.^[16, 31, 32] Lu *et al.*^[33] obtained ten genome sequences of SARS-CoV-2 from nine patients BALF and the samples were analysed by metatranscriptomic sequencing. All the genome sequences displayed more than 99.98% sequence identity. These next generation sequencing methods show a higher sensitivity than conventional RT-PCR, and can meet the needs of secondary detection, double-check diagnosis and large-scale suspected sample detection of RT-PCR false-negative samples.^[33] The work of Li *et al.*,^[16] suggested that NTS is the most suitable for the identification and mutation monitoring of SARS-CoV-2. However, the high cost of equipment and chemicals required for genomic sequencing methods restricts its utilization in routine SARS-CoV-2 laboratory diagnosis.^[14]

3.4 Computed tomography (CT) scan

Many researchers recommend the use of Computed tomography (CT) scan as one of the necessary auxiliary diagnostic method for SARS-CoV-2. This is linked with its high sensitivity.^[34] According to a recent report from Wuhan, the CT is significantly more sensitive than PCR for SARS-CoV-2 suspected persons. The results concluded that in patients having negative RT-qPCR reports, more sensitive and accurate conclusion can be achieved using a combination of CT-Scan and other standard techniques like RT-qPCR or other sensitive diagnostic tests.^[15]

Moreover, the high-resolution CT of the chest, can serve as an essential tool for detection of SARS-CoV-2, at early stage and to take rapid and necessary intervention. Typical features by CT of SARS-CoV-2 patient include bilateral multi-lobar ground glass opacifications with differently distributions in posteriors and in peripheral, along with sub-pleura ascendance, thickened lobular septa with variable alveolar filling.^[34]

The CT scans are indicative and not confirmatory test for SARS-CoV-2. Several findings have revealed that CT scan can be a great diagnostic tool for the screening of SARS-CoV-2 patients especially in high prevalence or pandemic areas. The main challenge associated with CT scan is its inability to separate the cases of other viral or non-viral pneumonia and the hysteresis of the abnormal CT imaging.^[15, 34]

3.5 Viral culture

Virus detection based on culture provides much information for pathogenesis research, but due to the culture cycle is quite long (usually 5-15 days), it is not recommended as a routine diagnostic procedure especially in severe cases.^[35] If the virus is to be cultured, the required biosafety regulations must be maintained throughout.^[16]

Viral culture is important especially for research purposes, as it enable the isolation of the virus, studying the properties of the virus, vaccine development, development of therapeutic agent and new or better diagnostic techniques.^[13] SARS-CoV-2 is isolated and propagated in primary monkey cells and cell lines such as the Human airway epithelial cells, kidney Vero-E6, Vero-E6/TMPRSS2 (Transmembrane Serine Protease 2), LLC-MK2, and Human hepatoma cell line Huh7.^[5, 20]

Apart from the long culture cycle, viral culture has the disadvantages that it requires a high technical expertise, and high cost of management of a Biosafety regulation, such as the biosafety cabinets etc. At present, samples for SARS-CoV-2 culture can be done in the US CDC laboratory in Atlanta Georgia, or the WHO reference testing laboratories in France, United Kingdom, China, Japan, Singapore, Australia, Thailand, India, USA, South Africa, Senegal, Russian Federation, Germany, and The Netherlands.^[20, 29]

These increases the overall cost and the Turn Around Time (TAT) for the disease diagnosis even when they are shipped as expedited consignments.

The currently available diagnostic methods presently in use are summarised in (Table 6).

Table 6: Current Diagnostic Methods Available for SARS-CoV-2

Method	Principle	Advantage	Duration	Disadvantage
Next generation sequencing (NGS)	Whole genome sequencing	Highly sensitive and specific, Provide all related information, Can identify novel strain	1–2 day	High expertise Equipment dependency and high cost Highly sophisticated Lab required
RT-PCR	Specific primer-probe based detection	Fast results Higher sensitivity Needs small amount of DNA Can be performed in a single step Well established methodology in viral diagnostics	3–4 h	Higher costs due to the use of expensive consumables Expensive lab equipment Detection is also complex and time consuming
LAMP	More than two sets of specific primers pair based detection	Highly repeatable and accurate Single working temperature	1 h	Too sensitive, highly prone to false positives due to carry-over or cross contamination
Serological (traditional)	Antigen/Antibodies IgG/IgM	Sensitive and specific	4–6 h	Testing come after 3-4 days of infection False positive
Rapid Serological	Antigen/Antibodies IgG/IgM	POCT	15–30 min	Testing come after 3-4 days of infection, False positive
CT scan	Chest images	Enhance sensitivity of detection if findings combined with RT-PCR results	1 h	Indistinguishability from other viral pneumonia and the hysteresis of abnormal CT
Virus culture and isolation	In vitro live virus isolation and propagation	Highly (100%) specific Gold standard	5–15 days	Low sensitivity as isolation is not 100%

Adapted from Kumar^[15]

3.6 Biomarkers of SARS-CoV-2 Disease Progression

Biomarkers are molecules that are measured and evaluated as an indicator of normal biological processes, pathogenic processes, or pharmacologic responses to therapeutic interventions.^[20] Biomarkers can be used as a tool to predict the onset and severity of SARS-CoV-2, along with the disease progression, identify the people at risk of contracting the disease, as well as the patients at risk for severe complications, in order to make an informed decision as whether to initiate an antiviral, anti-inflammatory, anticoagulant, or supportive therapy.^[17] These laboratory tests can further be used to predict disease mortality among patients, individual's predisposition to disease and the design of personalised drug therapies.^[18]

The biomarkers produced by the human body includes; interleukin-6, ferritin, lactate dehydrogenase, lymphocyte count, troponin, T, D-dimer, C-reactive protein and neutrophil-to-lymphocyte ratio^[17].

Table 7: Biomarkers of SARS-CoV-2 Disease Progression

Test Category	Biomarker
Hematologic	Lymphocyte count
	Neutrophil count
	Platelet count
	Albumin
	Creatinine
Biochemical	Lactate dehydrogenase
	Cardiac troponin
	B-type natriuretic

	peptide
	Oxygen saturation
	C-reactive protein
Inflammatory	Ferritin
	Procalcitonin
	Interleukin-6
Coagulation	D-dimer

Adapted from Chu^[22]

4.0 Biosafety Regulations

Laboratory investigation of SARS-CoV-2 infections present significant biological hazards for workers. Standard laboratory practices for handling SARS-CoV-2 clinical samples, such as specimen collection, storage, packaging and transportation, have been established to prevent accidental laboratory infections. The WHO recommends that all procedures must be performed based on risk assessment and only by highly trained personnel, in strict observance to all relevant protocols at all times. It is recommended that all SARS-CoV-2 specimens collected for laboratory investigation should be considered potentially infectious.^[4, 29]

As per WHO biosafety guideline, Non-propagative diagnostic laboratory work, such as genome sequencing and nucleic acid amplification tests, must be conducted under the assigned procedures and containment facilities equivalent to biosafety level 2 (BSL-2), while propagative work that involves SARS-CoV-2 inoculation, culture, isolation, or neutralization assays must be done in a high-biocontainment laboratory with inward directional airflow (minimum BSL-3). The facility must be equipped with respiratory protection along with a designated area for personal protective equipment (PPE) changes.^[4] All cultures or isolates must be transported as UN2814, category A, 'infectious substance', affecting humans' and All specimens from suspected or confirmed patients must be transported as 'biological substance category B', UN3373.^[4, 32]

4.1 Biosafety levels

Biosafety levels are sets of biocontainment precautions required to handle various biological agents, with various level of hazards. The level of containment required to prevent accidental environmental contamination and accidental infections must be adjusted to counter the biohazard potential of the organisms handled in the laboratory.^[19, 29]

Laboratories are classified according to their containment potential, or biosafety level (BSL), and are designated as BSL-1 (the lowest), BSL-2, BSL-3, or BSL-4 (the highest).^[19, 32] Personnel in laboratories working at all biosafety levels must follow good laboratory practices that ensure basic cleanliness and limit contamination. Laboratory surfaces must be decontaminated after each work shift or whenever spills occur. As in clinical laboratories, personnel cannot consume food or drink in any manner and must wash their hands when leaving the laboratory. Access to this laboratory must be restricted to laboratory personnel alone.^[4, 29]

4.1.1 Biosafety Level 1 (BSL-1) laboratories

BSL-1 laboratories are used when working with organisms that present low risk of infections. On normal individuals, these group of organisms are not infectious, e.g. *Saccharomyces cerevisiae*, *Bacillus subtilis*. Example of such lab is the teaching laboratories, it requires a low level of protection, usually a protective barrier such as lab coats and gloves are required. BSL1 is the lowest level of containment and work can be done on an open laboratory bench.^[36]

4.1.2 Biosafety Level 2 (BSL-2) laboratories

BSL-2 laboratories are used when working with organisms such as Hepatitis A, B and C, and pathogenic strains of *Salmonella*, and *Escherichia coli* or *Streptococcus pyogenes* that present a moderate risk of infection due to accidental ingestion, percutaneous injection, or exposure to mucous membranes via aerosols.^[37, 38] BSL-2 requires adhering to all BSL-1 precautions along with the addition of other protection devices such as protective goggles, and face mask. More so, all procedures that may generate large volumes of organisms or aerosols must be strictly done in a biosafety cabinet. Most clinical, research and school laboratories maintain such level of containment.^[35, 38]

4.1.3 Biosafety Level 3 (BSL-3) laboratories

BSL-3 laboratories are used when working with pathogens such as SARS-CoV-1, SARS-CoV-2, *Mycobacterium tuberculosis*, *Yellow fever virus* etc., that have a very high potential for causing serious

and potentially lethal disease especially from aerosols. In addition to all the precautions undertaken in BSL-1 and BSL-2 labs, all entrance to BSL-3 (Figure 5) must be separated from areas of building, and the labs must be behind two sets of self-enclosing doors to limit the risk of aerosols escaping into the environment.^[37]

All windows must be sealed and any seams in the ceilings, floors or walls must be sealed and fitted with air filters to prevent accidental release of the pathogen from the laboratory. A ventilation system must be installed, which forces air to flow from clean areas of the lab to places where infectious or hazardous agents are being handled, as to allow for easy decontamination.^[38] Work must not be done on the open bench, and all procedures involving infectious material must be strictly done within a biological safety cabinet.^[38] All laboratory staffs must where applicable, be offered relevant immunizations to reduce the risk of accidental and unnoticed infections and be provided with medical surveillance facilities. furthermore, a laboratory specific biosafety manual must be drafted which entails how the laboratory must operate in compliance with all safety regulations. Specialized clinical, research, and teaching facilities must maintain BSL-3 safety levels.^[19] safety



Figure 5: A researcher working under a biosafety level 3 conditions, at the US Centre for Disease control, Atlanta, Georgia, with respirator inside a Biosafety Cabinet Source: USAMRIID.^[39]

4.1.4 Biosafety Level 4 (BSL-4) laboratories

BSL-4 laboratories are designed for maximum containment of life-threatening pathogens that have a high probability of transmission by aerosols and for which there is no available vaccines, treatment, or cure.^[38] In addition to BSL-1, BSL-2, and BSL-3 requirements, BSL-4 laboratories are generally set up as protective suit laboratories or cabinet laboratories. In a protective suit laboratory, all work must strictly be done in a class 2 biosafety cabinet by trained and authorised personnel wearing full-body positive pressure suit, fitted with air supplies and then a chemical shower for complete decontamination. In cabinet laboratories, all work must be done in a class 3 biosafety cabinet (Figure 6) and all materials leaving the cabinet must strictly be passed through an autoclave for decontamination. All persons entering this kind of lab, along with the time they enter or leave, must strictly be recorded^[37, 38] BSL-4 laboratories (Figure 7) are usually associated with government facilities such as the Centres for Disease Control and Prevention (Atlanta, Georgia, USA), State Research Centre of Virology and Biotechnology in Koltsovo, Russia, or university laboratories that specialize in infectious diseases.^[38] Examples of pathogens that must be manipulated in a BSL-4 facility are viral haemorrhagic fever (Lassa, Marburg, Ebola), SARS-CoV-2, Variola virus, Henda virus, drug-resistant *Mycobacterium tuberculosis*, and Nipah virus. Dangerous pathogens are also placed in this level until sufficient information are obtained, enough for a decision of either to continue working with them at such level or on other lower levels^[19, 38]



Figure 6: BSL-3 and BSL-4 cabinet lab capabilities, fitted with gloves box lines and systems for All Hazard Receipt Facilities (AHRF) where samples must be handled at the highest levels of containment Source: Germfree. ^[40]



Figure 7: Trained and authorised personnel's working in a BSL-4 laboratory wearing full-body positive pressure suit, fitted with air supplies (the positive pressure suit is completely attached with the personnel in A, while in B, it is attached with the facility) (Adapted from GERMFREE; USAMRIID). ^[39, 40]

6.0 CONCLUSION

Molecular assays can rapidly and sensitively identify pathogens in suspected or confirmed patients; however, RNA viruses display a huge number of genetic variants and mismatches of primers, probes, and target sequences which can lead to the reduced detection performance and high false-negative results. In addition to molecular tests and genomic sequencing, serological tests can be used as an additional test, (e.g. the detection of SARSCoV-2 IgM and IgG antibody in vivo) in other to boycott false negative results. However, serological tests require seroconversion and cannot be applied to early infection. As per WHO biosafety guidelines, Non-propagative diagnostic laboratory work that involves SARS-CoV-2, must be conducted under the containment facilities equivalent to biosafety level 2 (BSL-2), while propagative work must be done in a high-biocontainment laboratory (minimum BSL-3).

REFERENCES

1. Chinese Centre for Disease Control and Prevention, (CCDCP). Report of the WHO China Joint Mission on Coronavirus Disease 2019 (COVID-19), 2020;16-24 February 2020
2. Lippi, G., Salvagno, G. L., Pegoraro, M., et al. Assessment of immune response to SARS CoV-2 with fully-automated MAGLUMI 2019-nCoV IgG and IgMchemiluminescence immunoassays. ClinChem Lab Med. 2020b. Doi: 10.1515/cclm- 2020-0473.
3. Mummed, Y. Molecular Targets for COVID-19 Drug Development: Enlightening Nigerians about the pandemic and future treatment. Biosafety and Health, 2020; access address: <https://doi.org/10.1016/j.bsheal.2020.07.002> access date:17th/08/2020

4. World Health Organization, (WHO). Global surveillance for COVID-19 caused by human infection with COVID-19 virus: interim guidance, 20 March 2020. Geneva: WHO; 2020. access address: <https://extranet.who.int/iris/restricted/handle/10665/331506>. 2020f access date: 15th/07/2020
5. World Health Organization, (WHO). Laboratory testing for coronavirus disease 2019 (COVID-19) in suspected human cases: interim guidance, 2 March 2020. WorldHealth Organization; 2020a.
6. Ahmad, S., Abdul, H. S., Ali S., Mumtaz A., Shruti M. A Review of COVID-19 (Coronavirus Disease-2019) Diagnosis, Treatments and Prevention. *Eurasian Journal of Medicine and Oncology*. 2020; 4(2):116–125, DOI: 10.14744/ejmo.2020;90853
7. Lippi, G., Mattiuzzi, C., Bovo, C. and Plebani, M. Current laboratory diagnostics of coronavirus disease 2019 (COVID-19). *Acta Biomed*, Vol. 91, N. 2020a; 2: 000-000, DOI: 10.23750/abmv91i2.9548
8. Nigeria Centre for Disease Control (NCDC). COVID-19 Situation Report, Situation Report 188, Data as Reported and Accurate by NCDC as at midnight 3rd September 2020. 2020b; Thursday. access address: covid19.ncdc.gov.ng
9. Nigeria Centre for Disease Control (NCDC). COVID-19 Situation report, situation report 189, data as reported and accurate by NCDC as at midnight 4th September 2020Friday. 2020a; access address: covid19.ncdc.gov.ng
10. Nigeria Centre for Disease Control (NCDC). COVID-19 Situation report, situation report 186, data as reported and accurate by NCDC as at midnight 1st September 2020Tuesday. 2020c; access address: covid19.ncdc.gov.ng
11. Nigeria Centre for Disease Control (NCDC). COVID-19 Situation report, situation report 93, data as reported and accurate by NCDC as at midnight 1st May, 2020Sunday. 2020d; access address: covid19.ncdc.gov.ng
12. Nigeria Centre for Disease Control (NCDC). COVID-19 Situation report, situation report 154, data as reported and accurate by NCDC as at midnight 31st July 2020Friday. 2020e; access address: covid19.ncdc.gov.ng
13. Padhi, A., Swatantra K., Ekta G., and Shailendra K. S. Laboratory Diagnosis of Novel Coronavirus Disease 2019 (COVID-19) Infection. Chapter 9: Coronavirus Disease 2019 (COVID-19), *Medical Virology: from Pathogenesis to Disease Control*. 2020; https://doi.org/10.1007/978-981-15-4814-7_9
14. Yuanyuan, X., Zhong, P., Caixia, T., Xiujian, M., Xun, H., Anhua, W., Chunhui, L., (2020). Diagnostic Options for Coronavirus Disease 2019 (COVID-19). *Infection Control & Hospital Epidemiology*.2020; DOI: 10.1017/ice.2020.168
15. Kumar, R., Suman, N., Samander, K. and Sanjay, M. COVID-19 diagnostic approaches: different roads to the same destination. *Virus Dis*. 2020; 31(2):97–105 <https://doi.org/10.1007/s13337-020-00599-7>
16. Li, C., ChengxueZhaoa, JingfengBaoa, Bo Tangb, YunfengWangc, Bing Gu. Laboratory diagnosis of coronavirus disease-2019 (COVID-19). *ClinicaChimicaActa*, 2020; 35-46. SARS<https://doi.org/10.1016/j.cca.2020.06.045>
17. Fang, F. C., Samia, N., N., Alexander, L. G. The Laboratory Diagnosis of Coronavirus Disease 2019—Frequently Asked Questions. *Clinical Infectious Disease*. 2020. DOI: 10.1093/cid/ciaa742
18. D’Cruz, Roshan, J., Arthur, W. Currier, and Valerie, B. Sampson. Laboratory Testing Methods for Novel Severe Acute Respiratory Syndrome-Coronavirus-2 (SARS-CoV-2). *Frontiers in Cell and Developmental Biology*, 2020; 468, doi: 10.3389/fcell.2020.00468
19. Centers for Disease Control and Prevention CDC. "Interim Laboratory Biosafety Guidelines for Handling and Processing Specimens Associated with Coronavirus Disease 2019 (COVID 19)". *Coronavirus Disease 2019 (COVID-19) Lab Biosafety Guidelines*. access address <https://www.cdc.gov/coronavirus/2019-ncov/lab/lab-biosafety-guidelines.html>. 2020b. accessed date 24 July, 2020
20. World Health Organization, (WHO). WHO-reference-laboratories-providing confirmatory-testing-for-covid-19.pdf. Accessed March 22, 2020. 2020c.
21. Chu, D. K. W., Pan, Y., Cheng, S. M. S., Hui, K. P. Y., Krishnan, P., Liu, Y., et al. Molecular diagnosis of a novel coronavirus (2019- nCoV) causing an outbreak of pneumonia. *Clin Chem*. 2020;66, 549–555. doi: 10.1093/clinchem/hvaa029
22. Chun, L., Ren, L. Recent progress on the diagnosis of 2019 Novel Coronavirus. *TransboundEmergDis*. 2020;67:1485–1491.
23. Broughton, J. P., Deng, W., Fasching, C. L., Singh, J., Chiu, C. Y., and Chen, J. S. A protocol for rapid detection of the 2019 novel coronavirus SARS-CoV-2 using CRISPR diagnostics: SARS-CoV-2

- DETECTR. Available: <https://mammoth.bio/wp-content/uploads/2020/02/Aprotocol-for-rapid-detection-of-the-2019-novel-coronavirus-SARSCoV-2-using-CRISPR-diagnostic-SARS-CoV-2-DETECTR.pdf>. 2020.
24. Centre for Disease Control and Prevention CDC. Tests for COVID-19. **access address:** <https://www.cdc.gov/coronavirus/2019-ncov/about/testing.html>. 2020a. Last accessed, April 15
 25. World Health Organization, (WHO). Advice on the use of point-of-care immunodiagnostic tests for COVID-19, Scientific brief of 8 April 2020. 2020d.
 26. Haveri A., Smura T, Kuivanen S, et al. Serological and molecular findings during SARS CoV-2 infection: the first case study in Finland, January to February 2020. *Euro Surveill.* 2020; 25(11). doi: 10.2807/1560-7917.ES.2020.25.11.2000266
 27. Jin Y, Wang, M., Zuo, Z., et al. Diagnostic value and dynamic variance of serum antibody in coronavirus disease 2019. *Int J Infect Dis.* 2020 Apr 3. pii: S1201 9712(20)30198-3. 2020; doi: 10.1016/j.ijid.2020.03.065. (Epub ahead of print).
 28. Lin, Q., Zhu, L., Ni, Z., et al. Duration of serum neutralizing antibodies for SARS-CoV-2: Lessons from SARS-CoV infection. *J Microbiol Immunol Infect.* 2020 Mar 25. 2020; pii: S1684 1182(20)30075-X. doi: 10.1016/j.jmii.2020.03.015. (Epub ahead of print).
 29. Mboowa, G. Current and emerging diagnostic tests available for the novel COVID-19 global pandemic. *AAS Open Research.* 2020; 3:8 <https://doi.org/10.12688/aasopenres.13059.1>
 30. GISAID.org **access address:** (<https://www.gisaid.org/>), **access date:** 25 June 2020
 31. National Health Commission of the Peoples Republic of China (NHCPRC). The diagnostically and therapeutic scheme for COVID-19(trial version 7). **access address:** <http://www.nhc.gov.cn/xcs/zhengcwj/202003/46c9294a7dfe4cef80dc7f5912eb1989.html>. Published 2020. Accessed July 24, 2020.
 32. World Health Organization, (WHO). Coronavirus disease (COVID-19) Technical guidance: Laboratory testing for 2019-nCoV in humans. **access address:** <https://www.who.int/emergencies/diseases/novel-coronavirus-2019/technical-guidance/laboratory-guidance>. 2020e. **access address:** 15th/07/2020
 33. Lu, R., X. Zhao, J. Li, P. Niu, B. Yang, H. Wu, et al. Genomic characterisation and epidemiology of 2019 novel coronavirus: implications for virus origins and receptor binding, *Lancet.* 2020; 395 (10224), 565–574.
 34. Pan, Y., Guan, H., Zhou, S., et al. Initial CT findings and temporal changes in patients with the novel coronavirus pneumonia (2019- nCoV): a study of 63 patients in Wuhan, China. *EurRadiol.* 2020; <https://doi.org/10.1007/s00330-020-06731-x>.
 35. World Health Organization, (WHO). Modes of transmission of virus causing COVID-19: implications for IPC precaution recommendations. Geneva: WHO; 2020b; [accessed 27 March 2020]. **access address:** <https://www.who.int/publications-detail/modes-of-transmission-of-virus-causing-covid-19-implications-for-ipc-precaution-recommendations>.
 36. Richmond, J. Y. "The 1, 2, 3's of Biosafety Levels" 2020; accessed 24 July, 2020
 37. Chosewood, L. C., Wilson, D. E., eds. *Biosafety in Microbiological and Biomedical Laboratories* (5th ed.). Centers for Disease Control and Prevention. 2020. ISBN 0-1608-5042-8.
 38. United States Department of Health and Human Services (USDHHS). "Section IV-Laboratory Biosafety Level Criteria". *Biosafety in Microbiological and Biomedical Laboratories*, 5th ed. 2016; 30–59.
 39. United States Army Medical Research Institute of Infectious Diseases (USAMRIID) **access address:** <https://globalbiodefense.com/2019/09/22/biosafety-levels-in-laboratories-what-is-the-difference/> **access date:** 4th/07/2020
 40. Germfree / Product Lines / Life Science Labs / BSL-3 Ag & BSL-4 Capabilities. **access address:** https://www.germfree.com/product-lines/life-science-labs/bsl-3-agbsl4capabilities/?gclid=Cj0KCQjwhb36BRcFARIsAKcXh6GYCbaAilets_RTv7N2wZwmRHPIbFZATNre8_7SCWBCLDjAv4_6gaAgvuEALw_wcB. **access date:** 4th/07/2020